

**DESIGN AND IMPLEMENTATION OF A SMART CONTROL SYSTEM FOR IMPROVED  
ESTATE MANAGEMENT**

**BY**

**NWANKWOEKE, VICTOR OKECHUKWU (B.ENG)**

**REG. NO: 20174080738**

**SUPERVISORS:**

**Engr. Prof. F.K. Opara**

**Engr. Dr. N. Chukwuchekwa**

**SUBMITTED TO**

**DEPARTMENT OF ELECTRICAL AND ELECTRONIC ENGINEERING**

**POSTGRADUATE SCHOOL OF ENGINEERING AND ENGINEERING TECHNOLOGY,  
FUTO**

**IN A PARTIAL FULFILMENT OF THE REQUIREMENTS FOR THE AWARD OF  
MASTERS OF ENGINEERING (M.ENG)**

**NOVEMBER, 2023**

CERTIFICATION

This is to certify that “**Design and Implementation of a Smart Control System for Improved Estate Management**” is original work done by **Nwankwoke, Victor Okechukwu (20174080738)** under the supervision of **Engr. Prof. F.K. Opara** and **Engr. Dr. N. Chukwuchekwa** presented to the Department of Electrical and Electronic Engineering, Federal University of Technology, Owerri, Imo State, Nigeria in fulfilment for the award of the degree, Masters of Engineering (M.Eng) in Electronic Engineering.

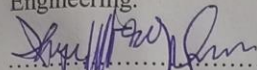
  
.....  
**Engr. Prof. F.K. Opara**  
(Supervisor I)

Date 11/12/24 .....

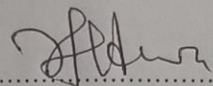
  
.....  
**Engr. Dr. N. Chukwuchekwa**  
(Supervisor II)

Date 18/12/24 .....

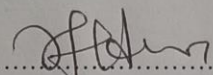
  
.....  
**Engr. Dr. N. Chukwuchekwa**  
(Head of Department.)

Date 18/12/24 .....

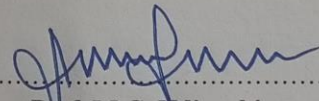
  
.....  
**Engr. Prof. M.C. Ndinechi**  
(Dean, School of Electrical Systems Engineering and Technology)

Date 18/12/24 .....

.....  
**Prof. B.O. Esonu**  
(Dean, School of Postgraduate Studies)

Date .....

.....  
(External Examiner)

Date .....

## **DEDICATION**

This work is dedicated to Almighty God, the Great Provider and Protector for assisting me in all ramifications.

## ACKNOWLEDGEMENTS

With a grateful heart, I want to seize this opportunity to express my unalloyed gratitude to my Lead Supervisor, Engr. Prof. F.K. Opara and Supporting Supervisor Engr. Dr. N. Chukwuchekwa, for their fatherly guidance and support.

I appreciate the contributions of my lecturers; Engr. Prof. G.A. Chukwudebe, Engr. Prof. E.N.C.

Okafor, Engr. Prof. M.C. Ndinechi, Engr. Prof. (Mrs) G.N. Ezeh, Engr. Prof. D.O. Dike, Engr. Prof.

(Mrs) I.E. Achumba, Engr. Prof. L.O. Uzoechi, Engr. Prof. J.O. Onojo, Engr. Dr. O.C. Nosiri, Engr.

Dr. C.K. Agubor, Engr. Dr. M. Olubiwe, Engr. Dr. I.O. Akwukwaegbu, Engr. Dr. S.O. Okozi and,

Engr. Dr. I.F. Ezebili (my course advisor during my B.Eng Program), Engr. N. Paulinus, and Engr. E.

Ugwueze.

Finally, I extend my thanks to my family members and well-wishers in the persons of Mr. David, Mr. Michael, Mr. Ndubuisi, Mr. Jeff, Engr. Jude (my first tutor in microcontroller programming), Emenike, and others.

## **TABLE OF CONTENTS**

Title Page	
Certification	ii
Dedication	iii
Acknowledgment	iv
Abstract	v
Table of Contents	vi
List of Tables	xi
List of Figures	xii
List of Plates	xiii
List of Abbreviations	xiv
<b>CHAPTER ONE: INTRODUCTION</b>	
1.1 Background of Study	1
1.2 Problem Statements	5
1.3 Objectives	5
1.4 Justification of Study	6
1.5 Scope of Study	7
<b>CHAPTER TWO: LITERATURE REVIEW</b>	
2.1 The Concept of Smart Estate	8

2.2	The General Advantages of Smart Home Automation	8
2.3	Review of Related Works	10
2.3.1	Automatic Transfer System (ATS)	10
2.4.1	Basic Features of Wireless Control	20
2.4.2	DTMF Signaling	24
2.4.3	GSM Mobile Phone Jammer	25
2.4.4	Research Gaps	27
 <b>CHAPTER THREE: MATERIALS AND METHODS</b>		
3.1	Materials	28
3.1.1	Materials for Automatic Transfer System (ATS)	29
3.1.2	Materials for Smart Energy Management System	30
3.1.3	Materials for Wireless Control of Appliances Using a Mobile Phone	30
3.1.4	Materials for Water Level Monitor and Controller	30
3.1.5	Materials for the wearable Security Aid device	31
3.1.6	Software Requirements	31
3.2	Methods	31
3.2.1	Hardware Connection Automatic Transfer System	32

3.2.2 Hardware connection for Automatic Wearable Alert System	32
3.2.3 Hardware Connection of the Automatic Smart Street Light Switch	33
3.2.4 Hardware connection for Automatic Water Level Monitor and Controller	34
3.2.5 Hardware Connection of Automation and Wireless Control of Electrical Appliances Using a Mobile Phone	34
3.2.7 General Hardware Connections of all four specific objectives in the research work	35
3.3 System Block Diagram	36
3.4 System Design	50
3.4.1 Printed Circuit Board Design used in assembling the electronic components	53
3.4.2 Design Specifications of ATS	55
3.4.3 System Circuit Design for the ATS	55
3.4.4 Design Specifications of the Wearable Alert System	56
3.4.5 Circuit Design of the Wearable Alert System	57
3.4.6: Design Specifications for the Smart Street Light Switch	58
3.4.7 System Circuit Design of the Smart Street Light	58
3.4.8 Design Specifications for the Smart Water Level Monitor and Controller	59
3.4.9 System Circuit Design for the Smart Water Level Monitor and Controller	60

3.5	Ultrasonic Sonar operation calculation and analysis	61
3.5.1	The Basic parameters are for the water level monitoring and control	61
3.6	System Circuit Design of Automation of Electrical Appliances	62
3.6.1	System Circuit Design of Automation of Electrical Appliances using IoT for easy remote load reprogramming and scheduling	62
3.6.2	Loads Calculation	64
3.7	System Circuit Design of Automation of Electrical Appliances	64
3.8	System Circuit Design of Automation of Electrical Appliances	64
3.9	General design component values and associated calculations	64
3.10	Principle of Operation of the Entire System	67
3.11	System Implementation	67
<b>CHAPTER FOUR: RESULTS AND DISCUSSIONS</b>		
4.1	Results	68
4.1.1	Test Result for the Smart Street Light Control	68
4.1.2	Test Result for the Automatic Transfer Switch	69
4.1.3	Test Results for the IoT-Based Real-time Communication System	70
4.1.4	Logic Gate for the Water Level Monitor & Controller	71
4.1.5	<b>CHAPTER FIVE: CONCLUSION AND RECOMMENDATIONS</b>	
5.1	Conclusion	73
5.2	Recommendations	73
5.3	Contributions to Knowledge	73
	REFERENCES	75
	APPENDICES	79

## **LIST OF TABLES**

Table 3.1: Design Specifications of the Automatic Transfer System

Table 3.2: Design Specifications of the Wearable Automatic Alert System

Table 3.3: Design Specifications of the Smart Street Light Switch

Table 3.4: Design Specifications of the Smart Water Level Monitor and Controller Table

## **LIST OF FIGURES**

Figure 2.1: Electrical Automation System

Figure 2.2: The flowchart of the System

Figure 2.3: Block Diagram Advanced Control Web-Based Home Automation with Raspberry Pi

Figure 2.4: RF System flowchart

Figure 2.5: Block Diagram

Figure 2.6: System block diagram

Figure 3.1: Overview System Block Diagram

Figure 3.2: The Flow Diagram of the System

Figure 3.3: Block Diagram of Automatic Transfer System

Figure 3.4: The flow Diagram of the Automatic Transfer System

Figure 3.5: The Block Diagram of A GSM Module Data Transmission

Figure 3.6: The Block Diagram of Smart Street Light

Figure 3.7: The Block Diagram of a Smart Water Level Monitor and Controller

Figure 3.8: Block Diagram of DTMF Decoder

Figure 3.9: PCB Component Layout

Figure 3.11: PCB Back Traces of Components

Figure 3.12: The Circuit Diagram of the ATS, Phase Selector with under/over voltage protection

Figure 3.13: Circuit diagram of the Wearable Alert System

Figure 3.14 Smart Street Light simulated result

Figure 3.15: System Circuit Design for the Smart Water Level Monitor and Controller

Figure 3.16: IoT Home Automation System Circuit Diagram

Figure 3.17: DTMF Circuit

Figure 3.18: System Circuit Design for the Mobile Phone Jammer

Figure 3.20: System Implementation

Figure 4.1 Graphical representation of the Analog vs Digital signal results

Figure 4.2: Normal Supply, Inverter, and Generator Output of Simulation

Figure 4.3a: Output of the IoT webpage (Off States of Loads)

Figure 4.3b: Output of the IoT webpage (On States of Loads)

## **LIST OF PLATES**

Plate 1 Graphical representation of the Analog vs Digital signal results	68
Plate 2: Normal Supply, Inverter, and Generator Output of Simulation	69
Plate 3: Output of the IoT webpage (Off States of Loads)	70
Plate 4: Output of the IoT webpage (On States of Loads)	71

## LIST OF ABBREVIATIONS

1. AC: alternating current	32
2. ADC: analog to digital converter	68
3. AGO: automatic gate opener	64
4. ATS: automatic transfer system	10
5. AWSS: automatic water supply system	3
6. DTMF: dual tone multi-frequency	29
7. GSM: Global System for Mobile Telecommunications	31
8. IOT: internet of things	40
9. IP Camera: internet protocol camera	7
10. LCD: liquid crystal display	28
11. LDR: light-dependent resistor	28
12. LED: light emitting diode	79
13. PCB: printed circuit board	5
14. SMS: short message service	31
15. UWS: uninterrupted water supply	60

## ABSTRACT

Nowadays, remote Home Automation turns out to be more significant and appealing. It improves the value of lives by automating various electrical appliances or instruments. This thesis centers on the design and implementation of a smart control system for improved estate management. The design and implementation of the system were achieved through the use of a Microcontroller and other units such as an IoT WiFi module, Internet Protocol (IP) camera module, Short Message Service (SMS) notification unit, and Automatic water supply and control unit. These modules or units were properly interfaced following the aim and objectives of the research work. The IoT WiFi module links the gadgets to the cloud where they can be remotely monitored and controlled. The IP camera connected to the WiFi module keeps the gadgets under control to be viewed from anywhere in the world. SMS notification, Automatic intruder picture notification, Automatic water supply, and control units interfaced with the

16. Arduino Microcontroller which addresses the issue of security warning and water wastage in the estate. The system has a control table from which the Estate Gadgets Control Manager (EGCM) can easily access and control the devices as the case may be through a mobile application. The completed prototype of the system is also capable of starting an electronic choke generator. The technologies deployed in the design of the system were WiFi and GSM network technologies.

17. **Key Words----- Automation, Arduino, IoT, IP camera, WiFi, ATS, RCoG, GSM and DTMF**

# CHAPTER ONE

## INTRODUCTION

### 1.1 Background of Study

Home automation refers to the use of smart devices and systems to control and automate various aspects of a residential environment, such as lighting, heating, ventilation, air conditioning, security, and entertainment. The integration of internet of Things (IoT) technologies into home automation systems has seen significant growth and innovation in recent years, leading to a proliferation of connected devices and applications aimed at enhancing convenience, energy efficiency, and overall quality of life for homeowners(Sahana et al., 2017).

The rise of the IoT has been driven by the increasing availability of high-speed internet connectivity, the miniaturization and cost reduction of sensors and processors, and the growing demand for smart, connected products. These developments have laid the foundation for the widespread adoption of IoT-enabled home automation systems, which have the potential to transform living spaces into interconnected, responsive environments. The study of home automation using the IoT seeks to understand the implications, challenges, and benefits of this technological integration, with a focus on its impact on daily routines, energy consumption, security, and user experience (Snehal, Bawane, Gautam, Ashish and Mishra, 2017).

From a technological perspective, the integration of IoT into home automation introduces unique challenges related to device interoperability, data security, privacy, and network reliability. Researchers in this field aim to address these challenges by developing robust communication protocols, security mechanisms, and interoperability standards that enable seamless integration and operation of diverse IoT devices within the home environment. Additionally, advancements in

artificial intelligence and machine learning have opened up new possibilities for making home automation systems more intelligent, adaptive, and user-friendly.

Socially, the study of home automation using the IoT examines how connected home technologies influence human behavior, social interaction, and overall well-being. It also explores the barriers to the adoption and acceptance of smart home devices among different demographic groups and cultural contexts. Understanding how people interact with and respond to IoT-enabled home automation systems is essential for designing products and services that align with users' needs, preferences, and values (Tadoju, 2015).

Economically, the proliferation of IoT-enabled home automation systems has implications for energy consumption, resource management, and the emergence of new business models within the housing and construction industries. The study of home automation using the IoT delves into the potential economic benefits of smart home technology, such as energy savings, improved property values, and new opportunities for service providers and technology vendors. Moreover, researchers investigate the impact of IoT on the development of smart cities and sustainable urban environments, where interconnected homes can contribute to more efficient use of resources and infrastructure.

In summary, the background of the study on home automation using the Internet of Things encompasses technological, social, and economic dimensions. This multidisciplinary field of research seeks to understand the complexities and opportunities that arise from integrating IoT technologies into residential environments, with the ultimate goal of creating smarter, more sustainable, and more comfortable living spaces for individuals and communities.

In recent times, people have been in the quest for approaches to improve life conditions, comfort, and as well the simplicity of handling or controlling electrical machines at the lowest cost. Many businesses today are also considering better ways to streamline their production activities and deploy automation where necessary in the production processes. In this process, it is more likely to see processes that rely on human decisions and manual observation and interaction in the industry (Nwankwoeke and Magbo, 2016). Automation of both home and industrial systems originated by paving a way for humans to apply general timings, and these actions take place within cycles of time smaller (milliseconds) than human perception” ( Taneja, Harsh, Gupta, Maansi, Kaushik, Prachi, and Delhi, 2019).

Estate Infrastructures mean the basic and fundamental facilities that help and are necessary to run an estate, such as road lines, sewage system, information and communication technology (ICT) facilities, mini mart or market, reliable power sources with energy management system incorporated automatic water supply system (AWSS) and so on. Energy management system will also be deployed, as this will help in optimizing power consumption or dissipation especially in the area of street lights switching off in the day time within the estate.

In an estate, the need for an impenetrable security measures to safeguard lives and property cannot be overemphasized. This calls for the deployment of security personnel at strategic locations within the estate. It is also important, to carry out selection, construction, and training of personnel in the use of safe room(s) located in the estate. Other estate security services include:

- i. **Estate Threat Assessment:** conducting a detailed security audit designed to identify and remedy security based issues centered on the clients of the estate.

- ii. **Effective Perimeter Security:** developing the appropriate security architecture while still maintaining the visual beauty of the estate.

The era of technology has redefined the media of communication. Greater number of people nowadays have access to mobile phones and thus the world indeed has become a global village. Global System for Mobile Communication (GSM) based remote management control is a subject of growing interest which has found applications in different areas. By harnessing the potentials of science, a highly secured and automated smart home system shall be demonstrated in this thesis and it is deployable to any world class estate. The main focus of this thesis is to develop a smart control system that can harmonize the operations of the estate infrastructures. To achieve the aforementioned features successfully, this research harnessed some of the key features embedded in cell phones which can enable us to operate our electrical appliances wirelessly and have dependable control of the infrastructures within the estate (automation).

This thesis ensures that unauthorized users are not permitted to access the control gadgets. To address this authentication feature, Mobile Phone Jammer, even though it's banned in some countries, but can still be deployed in a mobile jammer-licensed estate especially where top government officials stay. For the Mobile Jammer to restrict unauthorized users, the house owner should always switch ON the Jammer system before leaving the house especially when there is no plan of controlling any appliance remotely. Another interesting feature of this system is the ability to start or stop the portable generator set whenever the need arises by simply placing a call or by pressing a button on the keypad. This will help to curtail the regular occurrences of armed robbers attacking people as a result of coming out to switch off their portable generator set placed outside at late hours of the night. So, with this system, all these issues will be addressed.

## **1.2 Problem Statements**

As technology advances, modern lifestyle changes from obsolescence to comfortable, secure, and simplified environments such as a well-secured home or estate. In many estates, there epileptic power supply from the public utility. It is also a regular occurrence in some estates to witness armed robbers attacking people during switching off or on portable generators which are placed outside at night. People would rather choose to waste energy (leaving the gen set to run until fuel in the tank gets exhausted) than going out at late hours of the night to switch off or on of portable generator set due to fear of attacks.

It has been observed also, that there is ineffective and manual switching (control) of the power supply to borehole and swimming pool which contributes mostly to water wastage. In the areas of illumination of outside lightings and refreshing of the swimming pool reservoir, energy losses are encountered too. Some estates already have home automation of electrical appliances but the gadgets cannot be controlled or rescheduled remotely. In some countries where the global bioweapon attack (COVID-19) is still prevalent, physical contact with the valve of the water tap is prohibited. This research work tends to address the highlighted issues.

## **1.3 Aim and Objectives of the Study**

The aim objective of this thesis is the design and implementation of a smart control system for improved estate management. The specific objectives are to:

- a. Design printed circuit boards (PCBs) for the interconnectivity of the components using the easyEDA schematic software.

- b. Develop the front end of the webpage for local control of the devices using Cascaded Sheet Style (CSS) and Hyper Text Markup Language (HTML).
- c. With the IoT-based platform in (b) above, the mobile application is created to effectively interconnect with each button dedicated to the electromechanical relay for seamless control of the electrical loads in the house.
- d. Implement an IoT-based and real-time intelligent communication unit for remote visualization of the estates of the loads.
- e. Implement an autonomous unit for water supply management through the use of ultrasonic sensors and actuators (dc relays) for switching the water pump.

#### **1.4 Justification of Study**

Security and comfort environments are very pertinent for mankind. Considering the prevalent evil acts going in the societies today such as robbery attacks, kidnapping, stealing, vandalization of government property and other social vices, it is very crucial to develop an intelligent management system to assist occupants of an estate in their daily activities. Also, a system that can help them to checkmate intruders into their dwelling places because it has always been very suicidal where no state of the art security systems are deployed. This proposed research work will go a long way protecting lives and property of individuals in the estate.

## **1.5 Scope of Study**

The system design covers the Application based Camera Surveillance and Automation of Electrical appliances within a region of excellent Local or Wide Area Network strength for easy internet accessibility. The work uses hotspot technology which makes it controllable using any smart phone or computer. Also, the system is scalable and programmable to future Hotspot technology interfaces. The software requirement of the system is Web application. The hardware comprises Internet Protocol Camera, WiFi Module, Arduino Module and the Visual Display Unit. These hardware modules are programmed using Arduino C++ Programming language.

## **CHAPTER TWO**

### **LITERATURE REVIEW**

#### **2.1 The Concept of Smart Estate**

An estate is a large area of land in a country that is owned by a person, family, organization, or government. It can be referred to as a housing estate or an industrial estate

(<https://www.ldoceonline.com/dictionary/estate>, 2019). An estate consists of several buildings, a mini market, farmland, a microfinance bank, a water supply, a hybrid power supply, a conducive environment for recreational activities, security personnel, and so on. There are several types of estates with different characteristic features.

A home automation system is a type of technology that is specifically designed to control home appliances and devices automatically or remotely. This system makes use of various control systems to regulate the operations of appliances (Sehgal and Moore, 2017). Traditionally, electrical appliances were controlled using switches. However, with technological advancements, automation and wireless control of devices have become more popular, effective, and reliable (Nwankwoeke and Magbo, 2016)..

#### **2.2 The General Advantages of Smart Home Automation**

A smart home refers to a convenient home setup where appliances and devices can be automatically controlled remotely from anywhere with an internet connection using a mobile or other networked device. One might think of smart home automation as a nifty way to keep up with the latest technology, or an opportunity for home owners to show off, but there are some amazing (and indisputably) practical advantages to home automation.

The convenience factor here is enormous. Being able to keep all of the technology in one's home connected through one interface is a massive step forward for technology and home management.

Smart home systems tend to be flexible when it comes to the accommodation of new devices and appliances and other technology.

When one incorporates security and surveillance features in one's smart home network, one's home security can skyrocket. For example, home automation systems can link motion detectors, surveillance cameras, automated door locks, and other tangible security measures throughout one's home so one can activate them from one mobile device before heading to bed.

This is made possible since the systems are programmed to operate only when most needed.

Smart homes can also help one run one's appliances better. A smart TV will help one find better apps and channels to locate one's favorite program. A smart oven will assist one with cooking chicken to perfection -- without ever worrying about overcooking or undercooking it.

## 2.3 Review of Related Works

### 2.3.1 Automatic Transfer System (ATS)

An Automatic Transfer System (ATS) transfers the loads to the specific power source that meets the voltage level requirement. This keeps the power to the loads uninterrupted to ensure continuous operation of loads. ATS is required in developing countries where frequent power failure is an intense issue. Industries, schools, public and private sector organizations and even domestic users cannot tolerate power outage because it pushes them into losses in businesses, interrupts in normal official works, hindrances in routines and domestic activities (Amrutha et al., 2015).

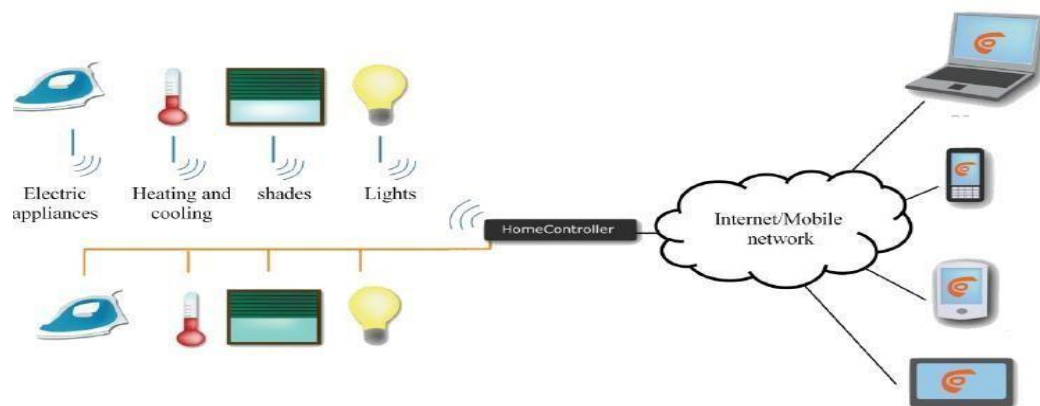

Figure 2.1: Electrical Automation System (Amrutha, 2015)

Industrial Automation Control Using Raspberry Pi and Zigbee was done by Chavan et al, (2017), the research investigated the industrial application of automation using Pi and Zigbee for the monitoring of industrial systems. They took a cursory look at how to achieve continuous monitoring of various industrial parameters. This task was accomplished by conjunction of the Zigbee module with the Raspberry Pi module. “The system incorporates a single master and multiple slaves with wireless communication medium and a system made of Raspberry Pi that could either operate on Windows or Linux operating system. The constraints that could be traced are temperature, light, intensity, and water

level. The hardware design was done with the surface mount devices on a double-layered printed circuit board to reduce the size and improve the power efficiency” (Vivek, Chavan and Jakhete, 2017).

The system was able to monitor and control all the parameters used in the industries and give accurate results of the system. The system was able to control various parameters of the industries like temperature, light intensity, liquid level of any fluid, etc. The system also provides monitoring of all the various parameters using the Zigbee module that can act as transceivers and provides monitoring over the large area of the industrial systems Chavan and Jakhete (2017).

IoT Based on Smart Interactive Office Automation by Rodge, Jaykant, Anup, and Pallavi (2017). In their research, the use of Internet of Things technology was deployed. The Internet of Things involves the interconnectivity of physical objects in such a way that one remotely controls them over the internet. Automation enables the partial or complete replacement of humans by machines. The projected system allows full control of any or all electrical devices in offices (Rodge, Jaykant, Anup and Pallavi, 2017).

Figures 2.2 and 2.3 show the microchip module used and the sequence of operations respectively.

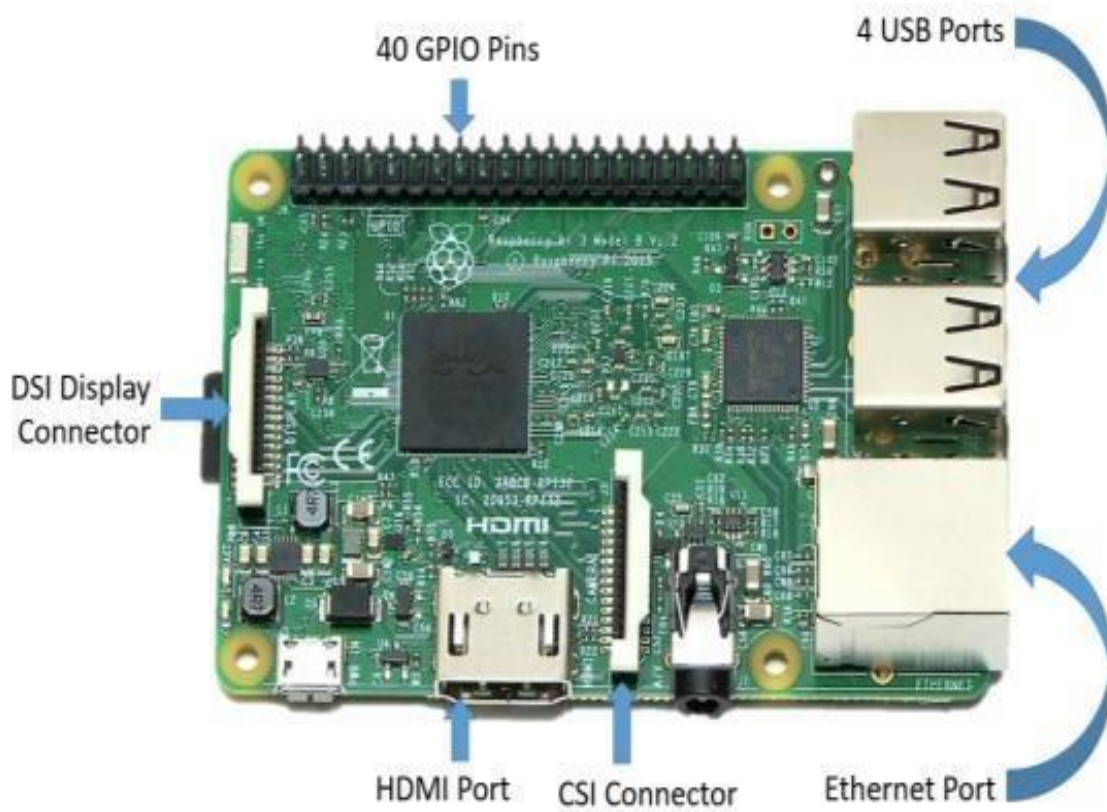

Figure 2.2: Raspberry Pi 3B IoT Based on Smart Interactive Office Automation (Rodge, 2017)

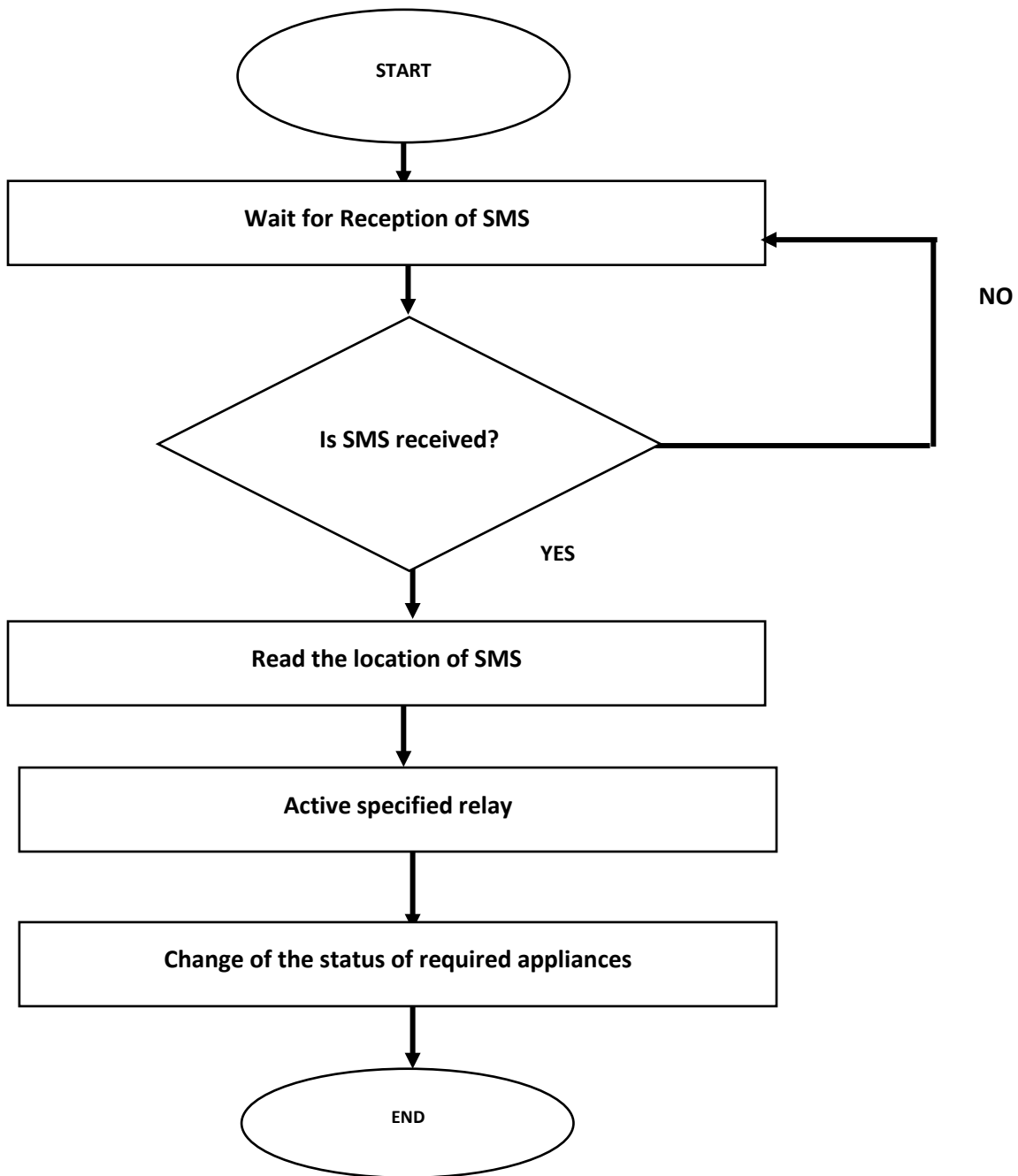

Figure. 2.3: The flowchart of the System (Rodge, 2017)

“At the end of the research, the result obtained showed that the IoT-based Automation of Office or home devices were controlled through a mobile phone. They also developed a mobile app that provided

an interface to control appliances. This method made it more comfortable and accessible to a particular appliance from mobile. The owner can also interact with the visitors without reaching the door.”

(Rodge, Jaykant, Anup and Pallavi, 2017). This Home Automation Android-Based GSM System by Snehal and friends, a GSM network was used to control electrical loads and also using a mobile application to do similar functions (Snehal et al.; 2018). The work also highlighted the need for home automation using Short\_message\_service (SMS).

### **Advantages**

1. maximum range using GSM technology
2. user friendly
3. easy to handle all people
4. low cost
5. power saving

### **Disadvantages**

1. If GSM network fails system doesn't work.

Advanced Control Web Based Home Automation with Raspberry Pi by Chavan implemented a system for control of electrical gadgets using web application and an intelligent module such as raspberry pi (Chavan and Snehal, 2017). Khulape also designed and implemented a cost-effective home automation system that is very efficient using web-application (Snehal and Khulape, 2018). This system was a user-friendly and safe system to control home appliances especially used by elders and Handicapped.

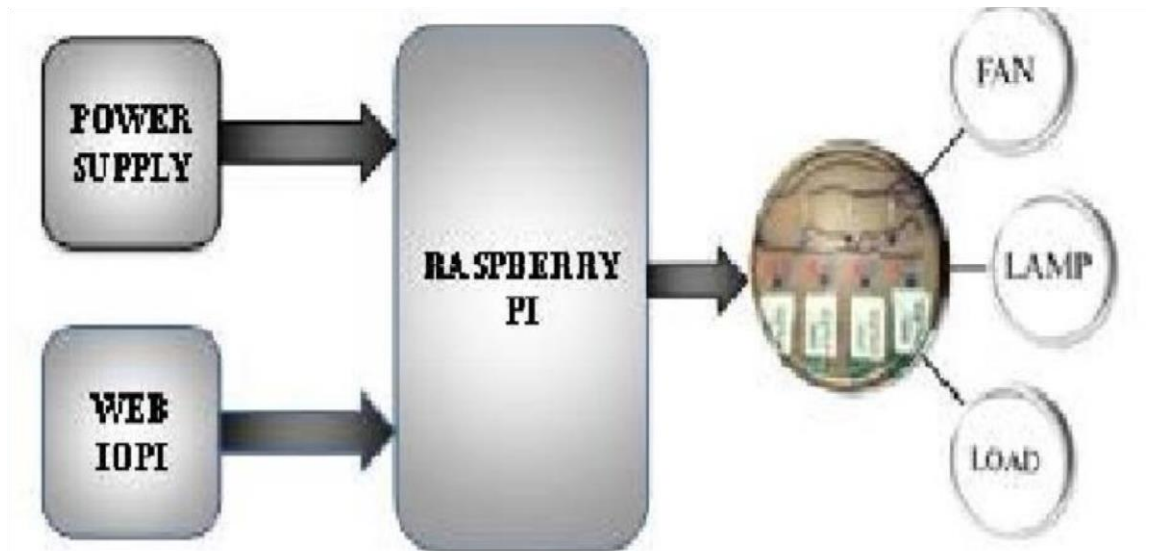

Figure 2.3: Block Diagram Advanced Control Web-Based Home Automation with Raspberry Pi (Ashok, 2017)

### Applications

- i. This technology is used in lightning control it is useful for saving energy by auto on or off in houses.
- ii. domestic application.

An RF Module-Based Wireless Secured Home Automation System Using Field Programmable Gate Array (FPGA) by Venkateswara (2015). The system made use of Wireless technologies like BTE and WiFi have been used in contemporary home security systems using low cost, low power, less complexity RF modules. It uses multi-hop communication for data transfer. Hence, to make this practically work one needs a compact Transmitter and receiver module which can operate at 433MHz (Venkateswara, 2015). RF (multi-hop technique) and Field Programmable Gate Array (FPGA) technologies. The system was developed using an RF Module wireless secured network (Spartan-3E FPGA). For Encryption and Decryption. RF 8-bit Module is used for Wireless Communication between FPGAs for 8-bit Transmission and Reception of Cipher Text. The figure. 2.5 shows the system flowchart.

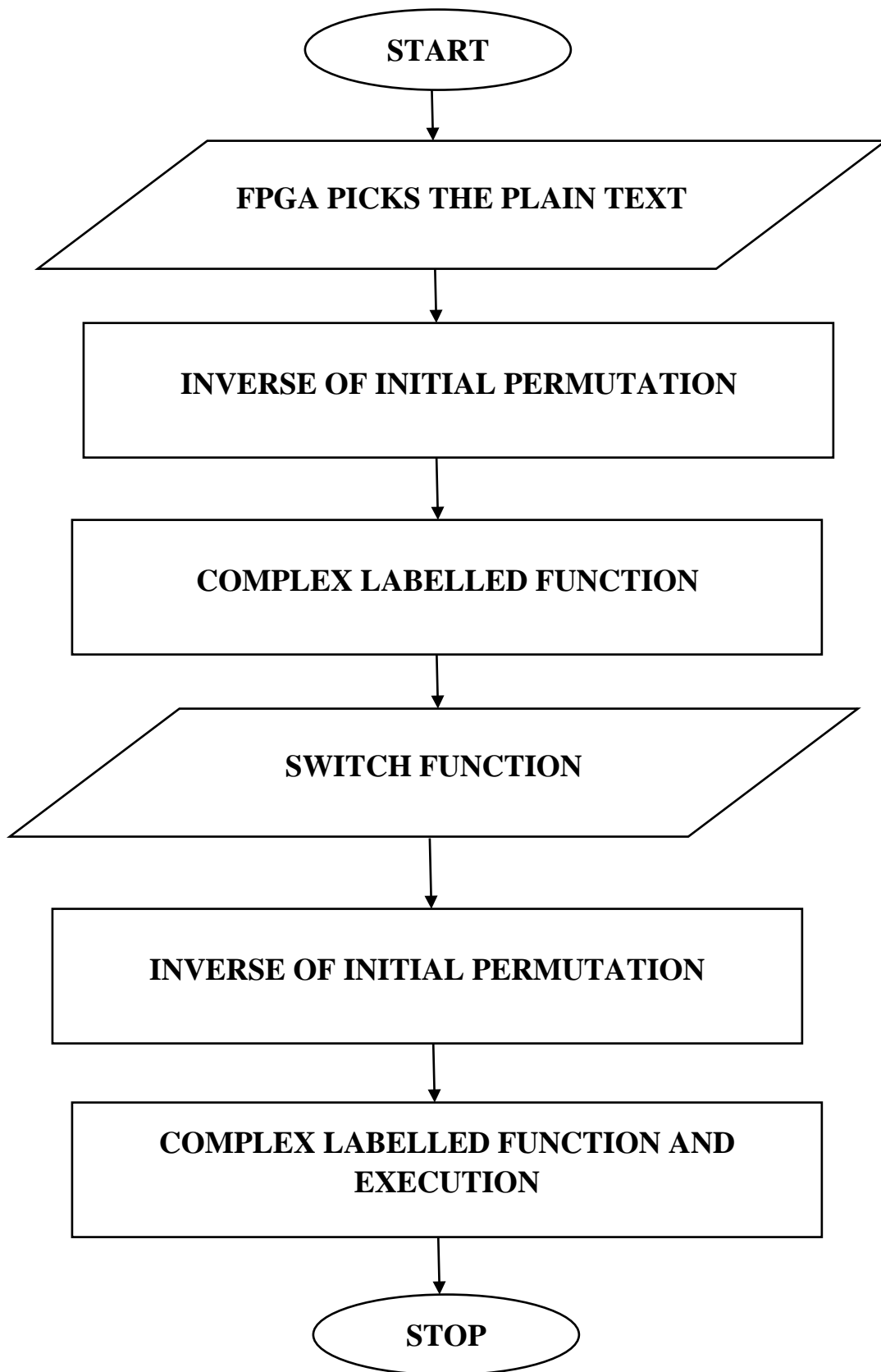

Figure 2.4: RF System flowchart (Kumar and Rao, 2015)

## Merits

- i. low cost
- ii. low power consumption
- iii. high efficiency
- iv. it allows data Encryption and Decryption for security.

## Demerit:

Its coverage depends on the frequency of the transceiver used.

A Speech Recognition Based Wireless Automation of Home Loads-E Home by Amrutha et al (2015), provided a system that was capable of voice recognition and the use of voice commands to handle office/home gadgets at a minimum cost both on operation and maintenance (Amrutha et al., 2015). Figures 2.6 and 2.7 on the next page demonstrate the block diagram and sequence of operations of the system model respectively.

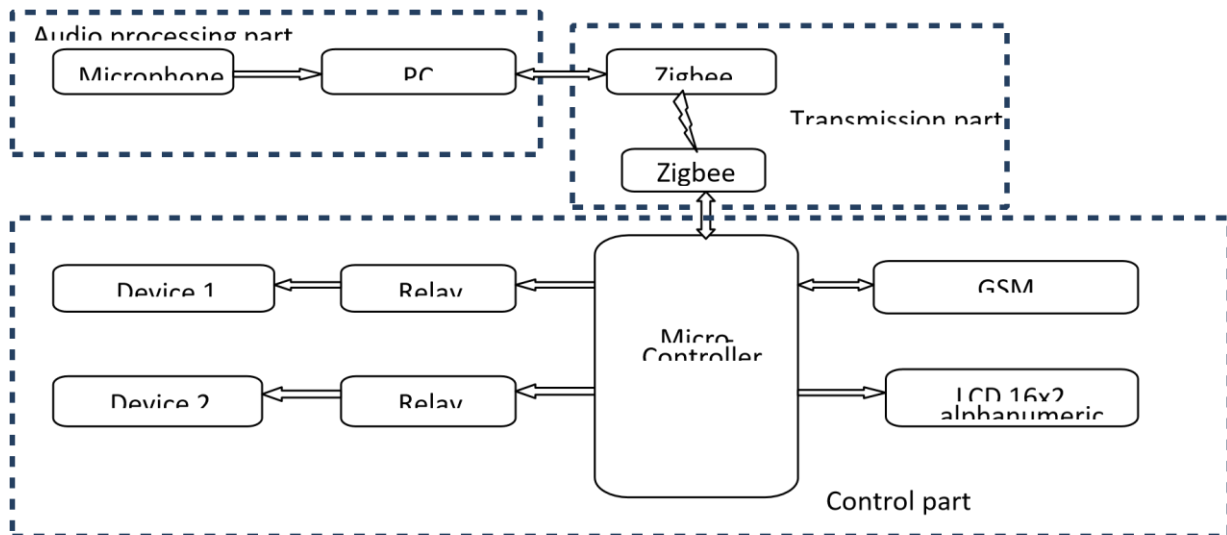

Figure 2.6: Block Diagram (Mathew et al, 2015)

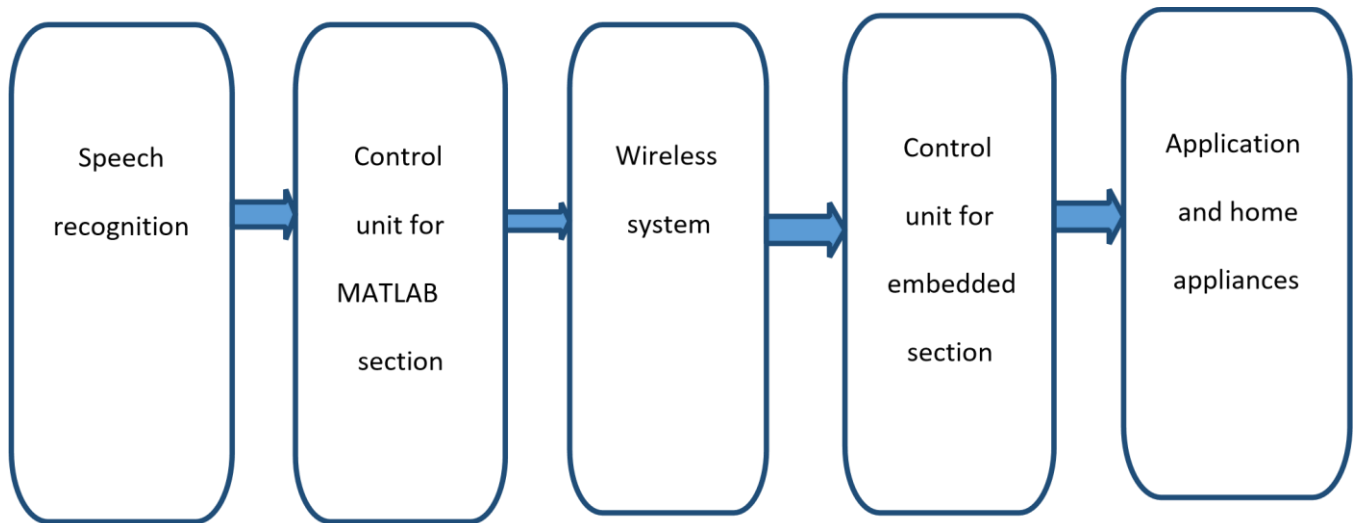

Figure 2.7: System model (Mathew et al, 2015)

**Technology Deployed:** SMS and DSP technologies.

**Materials used:** MATLAB/SIMULINK and Lab View

**Merit:** it only allows the voice of the trainer to issue commands hence, provides high security against intruders.

**Demerit:** a change in voice as a result of illness in form of cough and catarrh can affect the system drastically. These techniques were strictly followed to achieve the overall system hardware and software design and implementation of the smart home system for the aged persons.

Recently, different kinds of smart home systems have been developed by many organizations and institutions, and this was due to the fact that there is an increasing need of these kinds of homes. Most of the aged persons in Africa suffer from one kind of chronic illnesses, disabilities or the other, the

majority of them are living alone, and many others have cognitive impairments, especially in the oldestaged persons' group. It has been realized that there is a need for technology that can significantly offset the decline in health and self-care abilities and enable aged persons with or without disabilities to continue to live alone in a home. The whole purpose of the design of this smart home is to provide a safe, sound and secure living environment to the aged persons who are living alone at home.

A Bluetooth Remote Home Automation System using Android Application was done by Snehal (2017), the system was designed to meet the vital needs of the elderly and the physically handicapped (Snehal, 2017). It makes device control easier and faster for the aged. The figure. 2.8 shows the system block diagram.

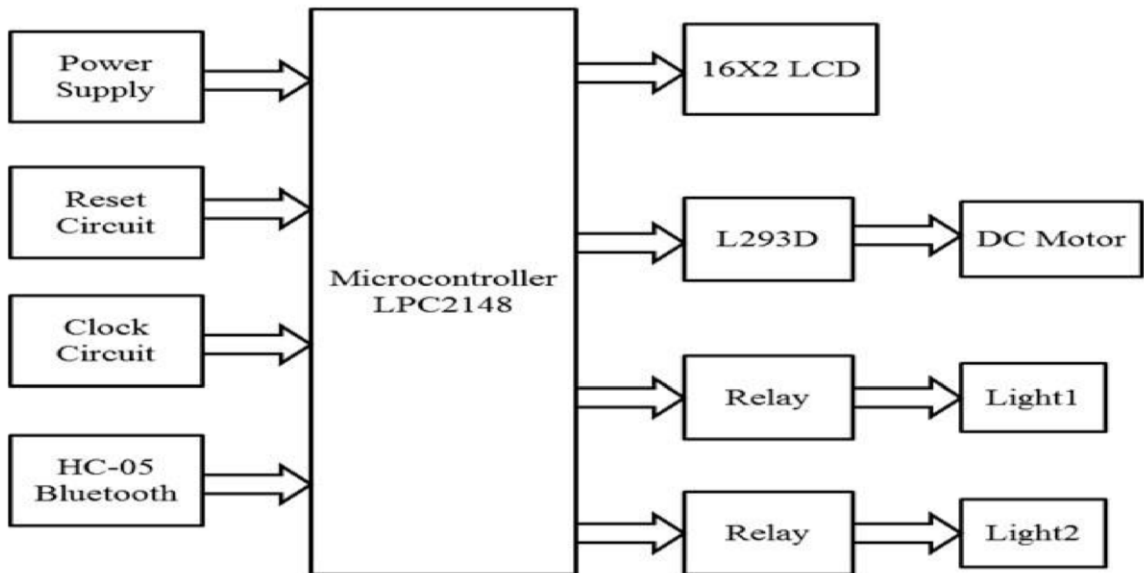

Figure. 2.8: Bluetooth Remote Home Automation System block diagram (Adoju and Ahesh, 2015)

A Home Automation using Global System of Mobile communication; Wireless control of electrical devices system used Simcard which enabled the users to link each other (devices) irrespective of



- i. with this system designed for wireless control of electrical appliances, there is no risk for false switching or debouncing of a switch.
- ii. this system is easy to implement and control.
- iii. before changing the state of any device under control, one can confirm the present status of the device.
- iv. this system is well-protected from unauthorized access as it is protected with a password and jammer circuit that allows only the user to control it remotely.

Wireless control of appliances using Dual Tone Multi Frequency Technology (DTMF) Dual tone multi frequency technology (DTMF) detection is the main object before starting to control the electrical appliances, the principle of the DTMF is that it takes a number code from the number pad converts it to DTMF signal and a DTMF decoder converts the DTMF signal to a digital code that can be fed to a microcontroller. (Nwankwoeke and Magbo, 2016). This technology broadly focuses on two areas which basically involves the DTMF Signaling and DTMF Detection.

A Smart Home with NodeMCU using IOT: An advanced home automation system was designed by Bhandari and Roshni using internet of things for a better home security which in turn reduces most of the human interfaces. This work could be enhanced to accommodate more features such as energy management systems , surveillance units, biometric access and so on (Bhandari, 2020).

A Bluetooth-based Home Automation using Arduino by Muthukumaran Kannusamy, Kanagaraj, and Guruveswaran (2019), used Bluetooth technology for wireless communications. The technology deployed here was good to a great extent but couldn't provide communications beyond 10 meters away

from the home or office where the gadgets were positioned. The short-range problem remains an issue with Bluetooth technology (Muthukumaran et al., 2019).

Economical Home Automation System using Arduino UNO by Kumar, which demonstrated the unique approach of achieving energy management system using Arduino microcontroller and current sensor. The thesis offers a user friendly automation-system with low price and decent performance. The operator sends commands through the android application which is linked to Arduino Uno with the aid of Bluetooth then the electrical machines of a home could be controlled. Smart or intelligent automation comprises the controlling and automation of electrical gadgets such as fans, lights, air conditioners, heating, and other home devices that use Bluetooth or Wi-Fi. (Kumar, 2017).

Home Automation and Security System with Node MCU using Internet of Things According to Raju, the system on automation and security system using NODEMCU was very effective and offers a wide range of features to homes and offices. The system could monitor the temperature of homes and offices, check for possible intrusion of strangers, and dark period monitoring unit to ensure that the street light is switched on or off accordingly. With the aid of the Blynk Mobile App, the system works easily on the user's mobile phone regardless of the proximity (Raju Chandrani, 2020).

A Smart Home Automation System using Arduino and Android Application Mamun and Hossain developed a smart system that automated electrical gadgets using an Arduino microcontroller and mobile application for easy operation of home and office appliances (Mamun & Hossain, 2020).

WiFi Door Lock System Using ESP32 CAM Based on IoT: Prathapagiri and Eethamakula (Prathapagiri and Eethamakula, 2021) designed an Internet of things based WiFi door-lock security system engaging

the ESP32 Camera to monitor the status of the entrance door to an office. Figure 2.10 shows the working model of the system.

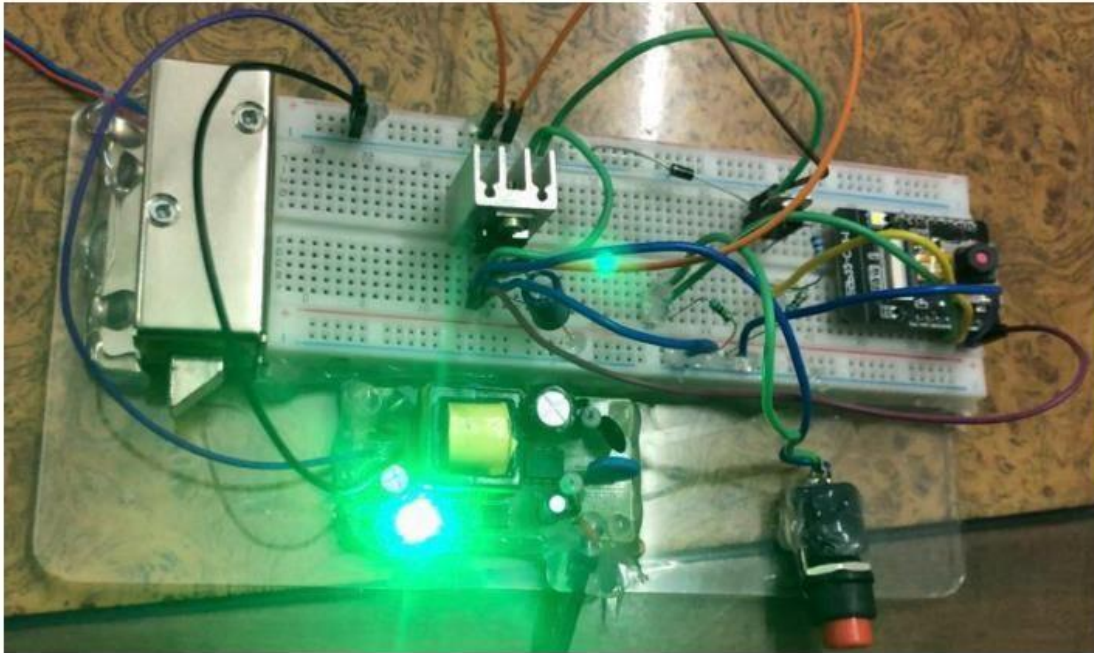

Fig. 3 Output of the working model

Plate 2.2: Working Model of WiFi Based security system (Prathapagiri and Eethamakula, 2021)

According to Kantha and Priyanka, (Kantha and Priyanka, 2020) the successful completion of their research work on Realization of an IoT System to Ensure Doorway Security by Integrating ESP32CAM with Cloud Server gave rise to a smart system that is capable of remote monitoring and but the work did not go beyond local area network server. Figure 2.11 shows the experimental setup of the system.

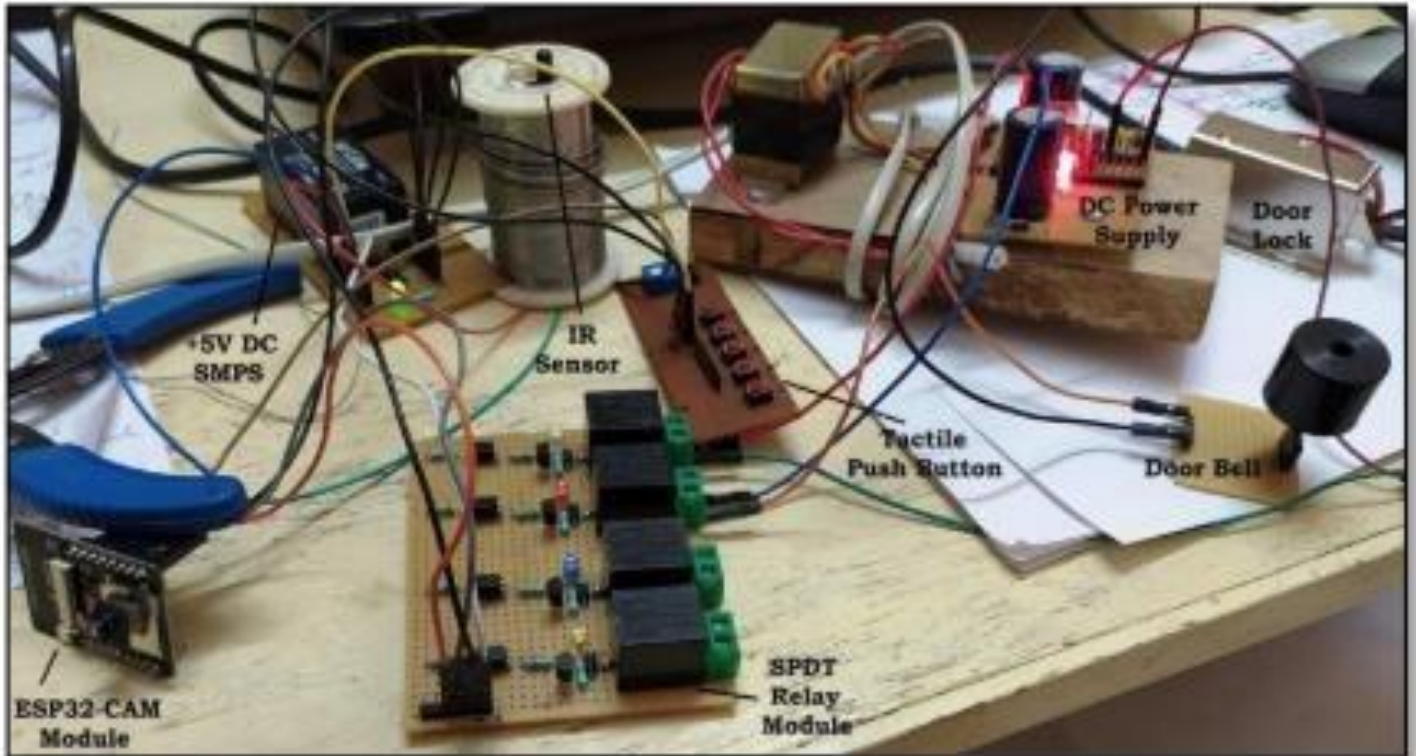

Plate 2.3: Experimental setup of smart monitoring system on a local server system (Prathapagiri and Eethamakula, 2021)

### 2.4.2 DTMF Signaling

DTMF signaling, increasingly being employed worldwide with push-button telephone sets, offers a high dialing speed over the dial-pulse signaling used in conventional rotary telephone sets. In recent times, DTMF signaling also found many applications such as automatic redial, modems that use DTMF for dialing stored numbers to connect with network service providers. DTMF has also been used in interactive remote access control with computerized automatic response systems such as airline's information systems, remote voice mailboxes, electronic banking systems, as well as many semiautomatic services via telephone networks. The DTMF signals are based on eight specific frequencies defined by two mutually exclusive groups. Each DTMF signal consists of two tones that must be generated simultaneously. Figure 2.11 clearly shows the telephone keypad matrix. One is chosen from the low-frequency group to represent the row index, and the other is chosen from the

highfrequency group for the column index. Telephone keypad matrix (Nwankwoeke and Magbo, 2016)  
 Then the logic equivalent of each frequency is listed in table 2.1. It is these stream of binary digits that are very important in assigning the Microcontroller what to do whenever a particular number is pressed on the keypad of the phone. One can represent them in hex format or binary depending on the language used in programming the Microcontroller.

Plate 2.8: Frequency Output of DTMF (Nwankwoeke and Magbo, 2016)

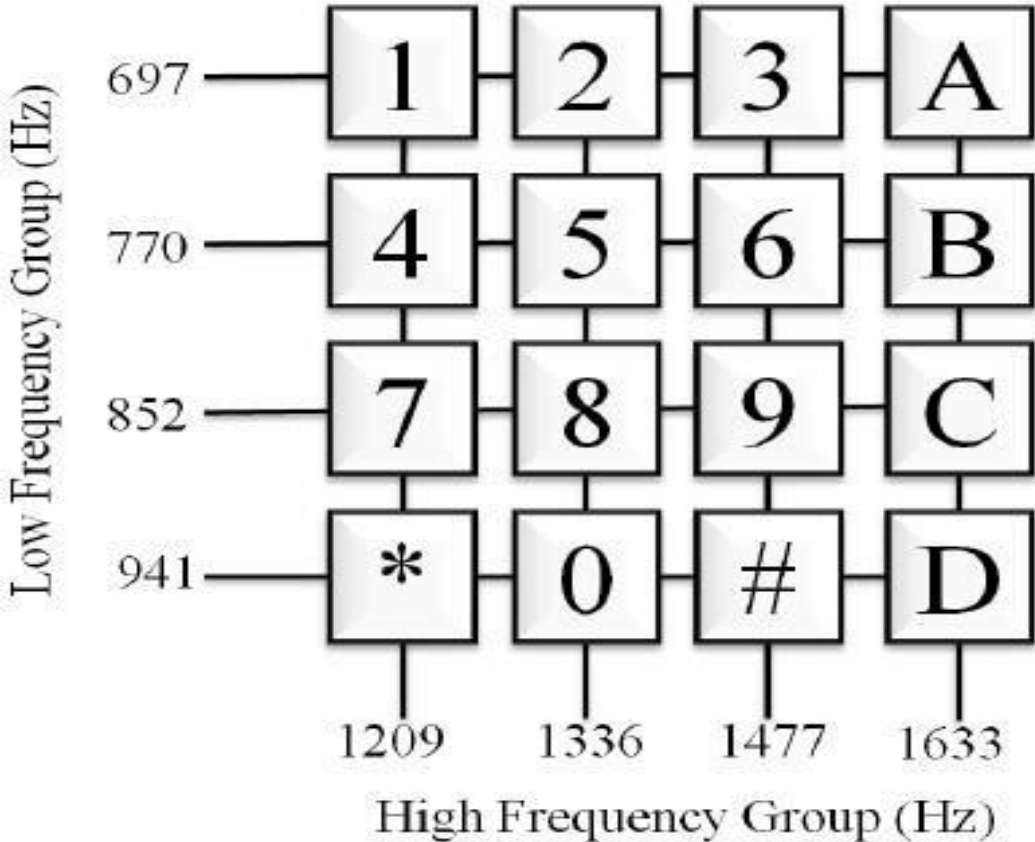

The implementation of a DTMF signal involves adding two finite-length digital sinusoidal sequences with the later simply generated by using look-up tables or by computing a polynomial expansion. By

pressing a key, for example number 3, it will generate a dual-tone consist of 697 Hz for the low group, and 1477 Hz for the high group (Debolina and Ria, 2015).

Table 2.1: DTMF LOW and HIGH Frequencies and the Binary Coded Output

Button	Low DTMF frequency (Hz)	High DTMF frequency (Hz)	Binary coded output			
			Q1	Q2	Q3	Q4
1	697	1209	0	0	0	1
2	697	1336	0	0	1	0
3	697	1477	0	0	1	1
4	770	1209	0	1	0	0
5	770	1336	0	1	0	1
6	770	1477	0	1	1	0
7	852	1209	0	1	1	1
8	852	1336	1	0	0	0
9	852	1477	1	0	0	1
0	941	1336	1	0	1	0
*	941	1209	1	0	1	1
#	941	1477	1	1	0	0

### **2.4.3 GSM Mobile Phone Jammer**

Communication jamming devices were first developed and used by military (Burton, Burpo, 2018). This interest comes from the fundamental objective of denying the successful transport of information from the sender (tactical commanders) to the receiver (the army personnel), and vice-versa. Nowadays, mobile (or cell) phones are becoming essential tools in daily living.

The two systems used the GSM technology (Shahdadpuri et al.; 2014). However, recently, there has been an increasing demand for portable cell phone jammers. Research Carried out by Nkwachukwu Chukwuchekwa on Interpolation Technique on Multirate Digital Signal Processing for Efficient Communication Systems revealed that smart systems need a digital signal processor for efficient data transmission during electrical switching of loads (Chukwuchekwa, 2011).

### **2.4.4 Research Gaps**

The following features have been identified as the research gaps between this project and the reviewed works.

- i. Ability to be reprogrammed wirelessly and remotely (from anywhere in the world provided there is internet connectivity).
- ii. Ability to be controlled manually in the event of poor network or low data subscription
- iii. It allows dual technology control (GSM and IoT).
- iv. Ability to accommodate a start and stop control of an electronic choke portable generator.

- v. Ability to control the Sumo and overhead tank concurrently. vi.
- Included a detachable or wearable unit for SMS security alert vii.
- Ability to view the gadgets under control via the Cloud.

## CHAPTER THREE

### MATERIALS AND METHODS

This chapter presents both the hardware and software used in the design and implementation of the proposed smart control system for estate gadgets management. The materials and methods used in the design are included in this chapter.

#### 3.1 Materials

The materials used are:

- i. **Arduino Microcontroller:** used for overall coordination of activities in the entire system. ii.
- GSM module:** this is the module for sending SMS in the event of an emergency.
- iii. **NodeMcu (WiFi module/ESP8266 Module):** used to link the objects to the internet for seamless remote control of gadgets.
- iv. **ESP32 CAMERA:** used to capture pictures of visitors or intruders and send them to the concerned estate dwellers regardless of the distance in the globe (with internet availability).
- v. **Relay module:** this is the electromechanical switch used in the switching of the electrical loads.
- vi. **Crystal oscillator (16MHz):** used for clocking microcontroller signal vii. **Light emitting diode (LED):** used as power on indicator viii. **Signal diode:** for creating polarity before the positive terminal of the battery. ix. **Voltage regulator:** used to regulate the voltage that goes into the microcontroller to 5V.

- x. **H<sub>2</sub>SO<sub>4</sub> and H<sub>2</sub>O<sub>2</sub>**: the two chemicals used for etching the printed circuit board (PCB) xi.
- Connector**: for making connections between two or more components. xii.
- Liquid crystal display (LCD)**: for visual display purposes.
- xiii. **DIAC and TRIAC**: used in conjunction with the Light-dependent resistor (LDR) for the outside light.
- xiv. **Lamp holder**: for connecting the AC loads (bulbs).
- xv. **AC bulb**: AC load to be controlled.
- xvi. **Universal programmer: used in programming (sending the written codes to the controller) the microcontroller.**
- xvii. **MT8870 DTMF Decoder**: used for the dual tone multi-frequency detection.
- xviii. **Light Dependent Resistor (LDR)**: used as the light sensor for proper monitoring of the outside lights and control.
- xix. **Actuators**: these include the pumping machine, relay for switching the gadgets, and indicator LEDs.
- xx. other discrete components.

### 3.1.1 Materials for Automatic Transfer System (ATS)

Materials for the automatic transfer system and specifications:

- i. **ATmega-328P Microcontroller**: used in the programming of the system for accurate selection of the available power source.
- ii. **5V, 10A Relay module**: used for power switching.

- iii. Bridge Rectifier (1N4007 for the Analog-to-Digital conversion (ADC) iv. Fixed Resistor (10K, 1K, and 100k): used as a current limiting resistor to the base terminal of the transistors used in energizing the DC relays.
- v. Capacitor (10uF/25V): used for filtration of possible AC ripples
- vi. A 3-core wire: used for component connection. vii. A 4-port connector for the Portable generator and public utility.

### **3.1.2 Materials for Smart Energy Management System**

Light Dependent Resistor (LDR), DIAC, TRIAC, and Fixed resistor (220K).

### **3.1.3 Materials for Wireless Control of Appliances Using a Mobile Phone**

- i. MT8870 DTMF Decoder: Used to interface with the mobile phone for DTMF detection and load control.
- ii. Crystal oscillator (3.35735MHz): used to generate the clocking frequency. iii. Signal diode (1N4007): used for impedance security. iv. Mobile Phone earpiece connector: used for connecting the DTMF decoder and mobile phone.
- v. NOKIA 105 with a registered SIM Card: used as the remote of the device under control.

### **3.1.4 Materials for Water Level Monitor and Controller**

- i. Arduino UNO Microcontroller: used to connect or disconnect the electric current to the connected water pump. This circuit is designed according to the Arduino microcontroller program, where there is a control signal from the Arduino microcontroller.
- ii. Ultrasonic sensor (HC-SR04): With ultrasonic sensors, we can find the water depth calculation by finding the distance between the transceiver and the surface of the water. The sensor will transmit a short ultrasonic pulse, and we can measure the travel time of that pulse (the echo) to the liquid and back
- iii. 8mm flexible pipe: used to link the water channels for easy flow.
- iv. 12V DC water Pump: used to power the DC water pump.

### **3.1.5 Materials for the wearable Security Aid device and automatic picture notification**

ESP32 Camera: Used for the IoT section of the security aid device in which the receiver (RX) pin connects to the transmitter (TX) pin of the controller. SIM900 shield module: this is used as mobile phone module for short message service (SMS) to the concerned authority. A registered and functional SIM card: this module gives network to the GSM module. Arduino mega 328p: this is the heart of the wearable device which controls every activity is sending SMS. Reset button: used in making the system to be restored to default settings in the event of any abnormalities. Wrist watch casing: used as the device holder for easy wearing. Insert the SIM card with an activated data plan to the GSM Shield. The RX GSM module connects to the Arduino via the TX pin. The RX Arduino controller connects to the GSM module via the TX pin.

### **3.1.6 Software Requirements**

Object-oriented programming C++ was used in programming the Controller. This programming language is based on a concept of objects that combine data and programming instructions (Opara, 2003). The following software applications were used Arduino C++, Embedded C Programming language, BASIC Programming language, Proteus simulation software, Archi CAD Software, Sprint Laonet software, Pad2Pad software, Mendeley software for references.

## **3.2 Methods**

The top-down method was adopted for this work. The individual block diagrams were discussed in details before harmonizing them to form the overall system. The major technologies deployed in this work included Internet of Things (IoT), Global System for Mobile Telecommunications (GSM), Internet Protocol (IP) Camera, Radio Frequency (RF) and Dual Tone Multi-Frequency (DTMF) technologies.

### **3.2.1 Hardware Connection Automatic Transfer System**

Three terminals of the General Purpose input/output (GPIO) terminals of ATMEGA328 Microcontroller were connected to the three Analog-to-Digital converter (ADC) circuits respectively. The three rectifier analogue to digital converter (ADC) sources represented the three Power sources (public utility, renewable energy and portable generator). The voltage levels were set for Low, Normal and High using the ADC and then calibrate them and assigned their corresponding values. The capacitor helps in filtering off ripples (escaped alternating current voltage) in ADCs to ensure that the controller receives a pure direct current (DC) signal. Then Arduino IDE code editor was used to write and upload the codes. The minimum voltage is 100V while the maximum is 240V. Any voltage level that is below or above the set-points is neglected by the controller, hence, no selection would be made on that particular phase. The compiler scans through the three phases (ADCs) and if a condition is true, a

transistor is biased in order to energize a relay for a proper switching of that particular phase. But if there is none that falls within the acceptable range (100 to 240V), the system displays “NO OUTPUT VOLTAGE” on the LCD.

### **3.2.2 Hardware Method for the IoT control of gadgets in the estate**

The node microcontroller unit (NodeMCU) WiFi module was solely responsible for linking the device to the internet for easy remote control. The actual connections between the Relay module and Nodemcu WiFi module were carried out in the following steps:

Connect the Vcc of the Arduino to the Vcc of the NodeMCU and GND of the Arduino to the GND of the NodeMCU. Then, connect the digital pin (D4) of the NodeMCU to the input terminal 1 of the Optocoupler-based relay module, connect the digital pin (D5) of the NodeMCU to the input terminal 2 of the Optocoupler-based relay module. Connect the AC mains cable to the Common pole of the relay and connect the load wire to the normally open of the relay module. Also, connect the Vcc of the relay module to the Vcc of both Arduino Controller and Nodemcu. Connections between the Arduino Controller and the Liquid Crystal Display (LCD) were carried out in the following steps:

Connect the Vcc of the Arduino to the Vcc of the LCD and GND of the Arduino to the GND of the LCD. Connect a current limiting resistor to the pin 15 of the LCD. The enable pin of the LCD Controller was connected to the digital pin 11 of the Arduino Controller, Register Select (RS) of LCD was connected to digital pin 12 of Arduino, the data pins of the LCD digital pin 7 (D7), digital pins 6 (D6), 5 (D5), and 4 (D4).

### **3.2.2 Hardware Connection for Automatic Wearable Alert System**

For the Security alert using GSM, a functional SIM card was inserted in the SIM900A module and then connected to Arduino Chip for an automatic mobile SMS messenger to the security personnel. C Receiver terminal (Rx) of the SIM900A was connected to the Transmitter terminal (Tx) of the Arduino chip and the Transmitter terminal (Tx) of the SIM900A to the Receiver terminal (Rx) of the Arduino chip. The common collector (Vcc) and ground (GND) terminals of the SIM900A to the Vcc and GND of the Arduino Controller respectively. Then the GSM Module (SIM900A) was booted for one minute in order to allow it to get network. This was done by monitoring the blinking rate of the status LED. Waited until it began to blink once per 3 seconds. A tiny keypad was connected to the SIM900A module with each key dedicated to a particular security alert when pressed. Arduino C IDE code editor was used in programming for communications between the SIM900A and Arduino chip.

### **3.2.3 Hardware Connection of the Automatic Smart Street Light Switch**

Connect a Light Dependent Resistor (LDR) in conjunction with Triac and Diac for an automatic switch for the Smart street light. Connect the LDR between the main terminal 1 and the gate. Connect a 220K ohm resistor between the gate and the main terminal 2. Then, connect a diac between the gate and the output wire. Feed the input voltage at the main terminal 1 and then connect the load (street light) to the main terminal 2.

### **3.2.4 Hardware connection for Automatic Water Level Monitor and Controller**

The echo terminal pin of the ultrasonic sensor was connected to pin 9 of the Arduino chip (ATMega328) and the trigger terminal of the ultrasonic sensor to pin 10 of the Arduino. Vcc and GND of the Controller to the Vcc and GND of the sonic sensor respectively. Then, Arduino Integrated Development Environment (IDE) was used in writing the code in line with the installed ultrasonic sensor library distance calibration was in centimeters and it was converted to meters. The sensitivity range of the sensor is about 0.02m to 4m minimum and maximum respectively.

### **3.2.5 Hardware Connection of Automation and Wireless Control of Electrical Appliances Using a Mobile Phone**

Controlling an electronic choke portable generator remotely, connect a cell phone (NOKIA 105) with a registered SIM card to the DTMF circuit. Set the phone to be on auto answer and the keypad should be outdoor. Now one can place a call on the phone number interfaced with the DTMF circuit. As the phone picks the call automatically, press any button of one's choice, monitor the output terminals and connect a Relay driver Integrated Circuit (ULN2003) to the corresponding outputs for an effective wireless control of electrical appliances. This is used in controlling the ON or OFF switch of the electronic portable generator and any other kind of appliances within the estate.

### **3.2.7 General Hardware Connections of all four specific objectives in the research work**

Adopting the survey method is a systematic method for gathering information from individuals to describe the attributes of the larger population of which the individuals are members (T. Dobrowiecki, 2005). A thorough survey was carried out at the Heartland Housing Estate, Owerri West, Portharcourt Road, Owerri, Imo State, Nigeria. It was observed that the stated problems in chapter one of this work were very prevalent, especially in the areas of epileptic Power Supply from the public utility and weak

communications amongst the Security personnel. An Oral interview was conducted during data gathering for performance analyses of the existing infrastructures within the estate.

However, this system deploys an ATMEGA32 Microcontroller in the design of the automatic transfer system (ATS) which has an Analog-to-Digital converter (ADC). Three rectifier circuits represent the ADC sources for the three power sources and the ATMEGA32 was programmed using BASIC Programming language. These ADCs were connected to the three power sources (public utility, portable generator, and renewable energy) for continuous scanning for the set voltage priorities.

Controlling an electronic choke portable generator remotely, connect a cell phone (NOKIA 105) with a registered SIM card to the DTMF circuit. Set the phone to be on auto answer and the keypad should be outdoor. Now one can place a call on the phone number interfaced with the DTMF circuit. As the phone picks the call automatically, press any button of one's choice, monitor the output terminals and connect a Relay driver Integrated Circuit (ULN2003) to the corresponding outputs for an effective wireless control of electrical appliances. This was used in controlling the ON or OFF switch of the electronic choke portable generator and any other kind of appliances within the estate.

Finally, set a smart phone with IP-webcam software (installed) and enter the IP address of the mobile phone on a browser on a Personal Computer (PC). The phone video camera starts remote monitoring.

### **3.3 System Block Diagram**

The general block and the flow diagrams that depict the entire system prototype are shown in Figures 3.1 and 3.2 respectively. Figure 3.8 shows the various sub-systems and how they interact to make up the entire system. The manager's or user's phone acts as the initiator of communications to other subsystems. The microcontroller is the brain of this entire system which coordinates activities based on the predefined instructions via codes. There are three phases under monitoring viz the public utility,

portable portable generator and renewable energy. Each of the phases acts an input by which the controller scans through in a cycle of 16 million times in a second (frequency of oscillation is 16MHz).

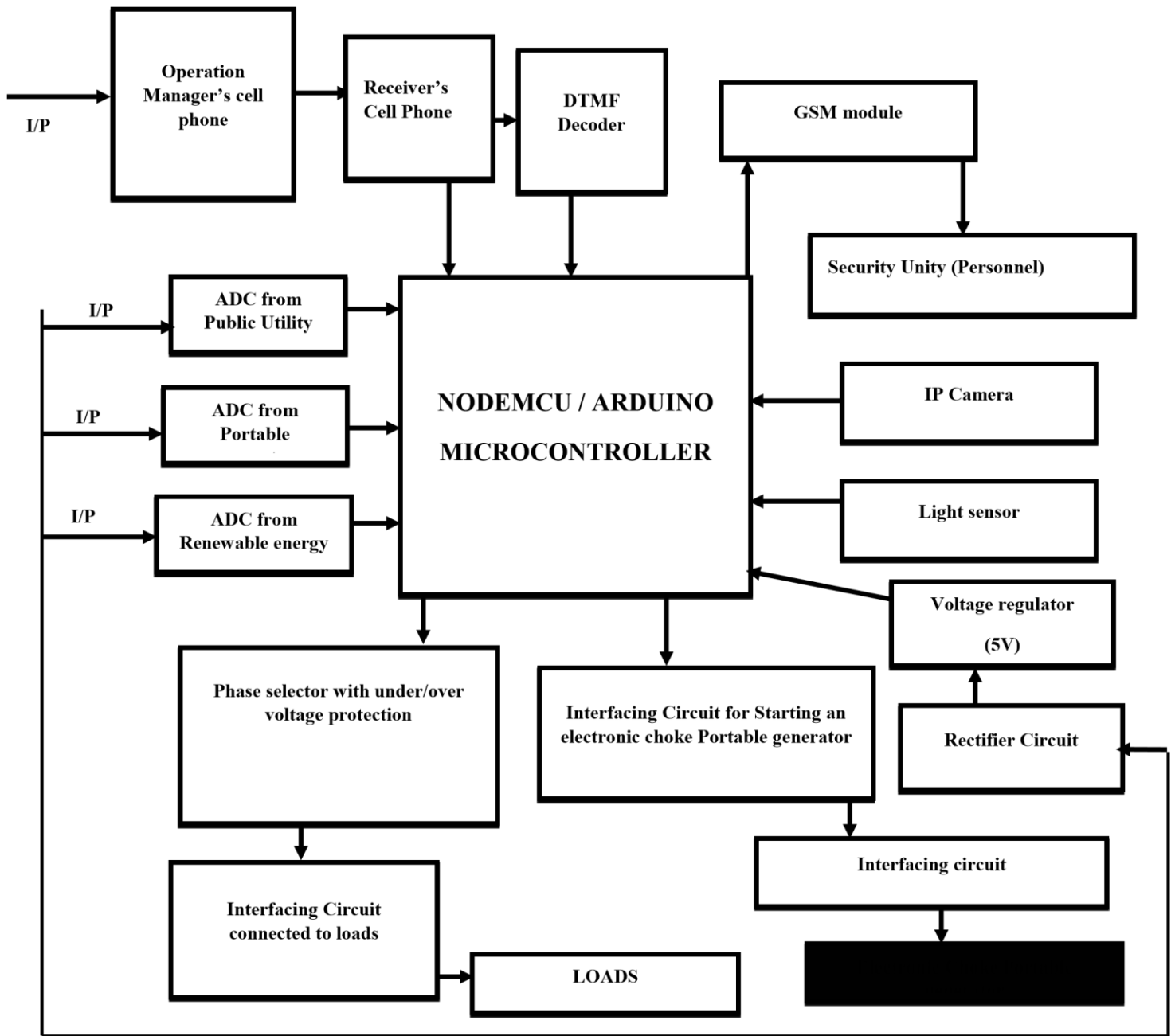

Figure 3.1: Block Diagram of a Smart Control System

Figure 3.2 shows the extension of the block diagram which included the smart security camera part of the system. It has a motion sensor for automatic capture and send of visitors or intruders pictures to the house owners. This helps the security personnel to alert the estate residents of the visitor's picture which makes identification easy.

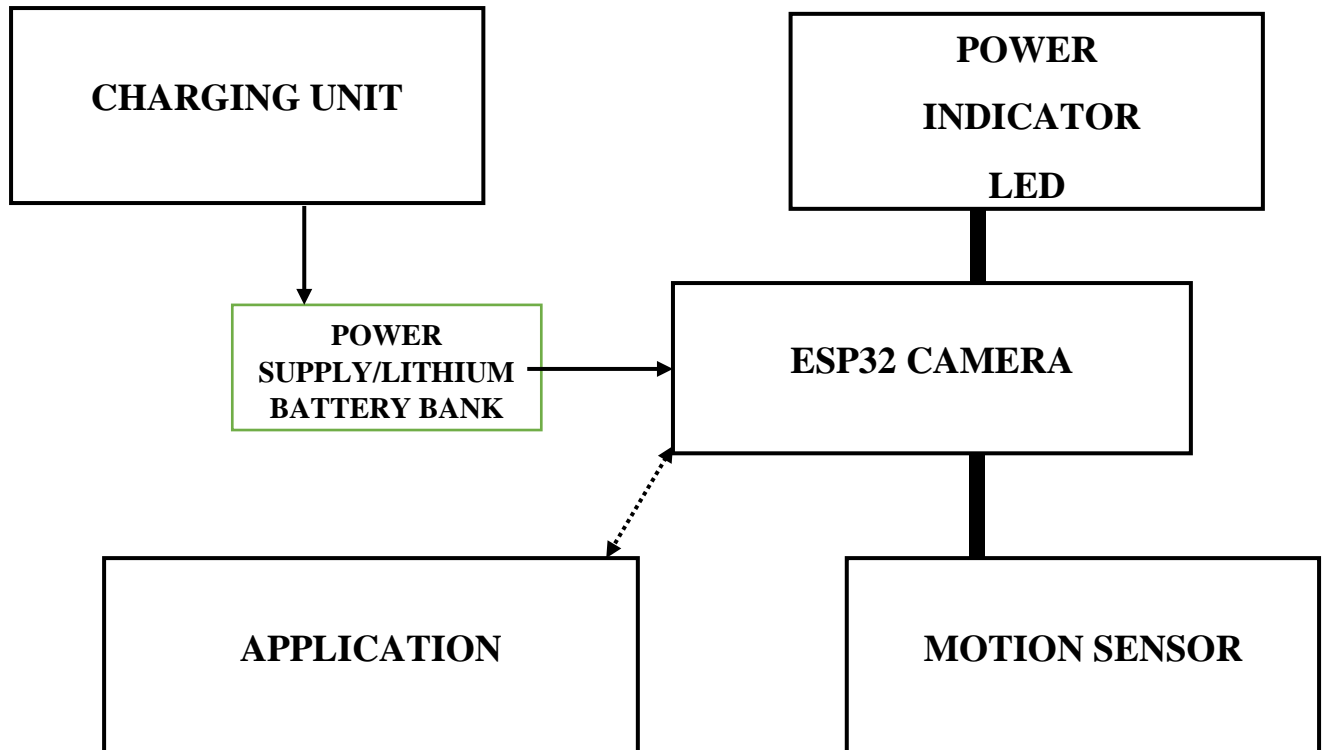

Figure 3.2: A Block diagram of a wireless Doorbell for a Smart home

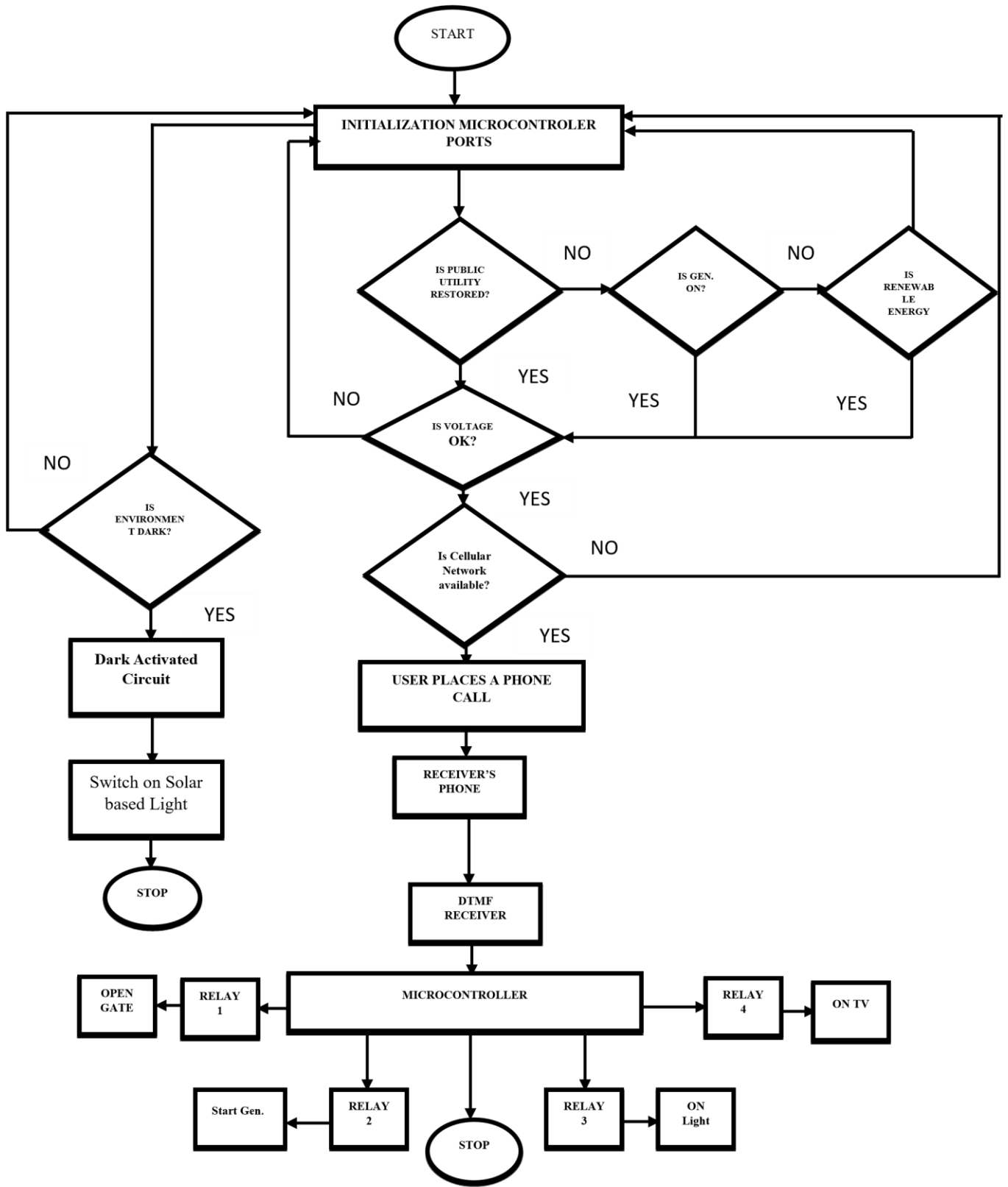

Fig.3.2: The Block Diagram of the Smart Control System

### 3.5 System Algorithm and Flowchart for the internet of things part

The following is the simplified system algorithm of the IoT sub-system:

- i. the system first turns on
- ii. the system initializes the input/output pins of the Arduino controller
- iii. the system also initializes the input/output pins of the Nodemcu controller
- iv. the scans for available networks in its vicinity and gets connected if available
- v. then makes its IP address available on the connected network domain
- vi. gets its input or output pins ready for easy communications on the web page
- vii. now ready to respond to the web page if opens on any browser (e.g Chrome, Firefox, Internet Explorer, etc)
- viii. responds to the online web digital button if pressed
- ix. turns on the gadgets under control
- x. toggles the state of the online web page if pressed the second time
- xi. turns off the gadgets under control
- xii. likewise, the Android phone webcam app initializes and gets set for remote viewing (surveillance of the appliances under control)
- xiii. the loop stops here and waits for the next process of execution of tasks if need be.

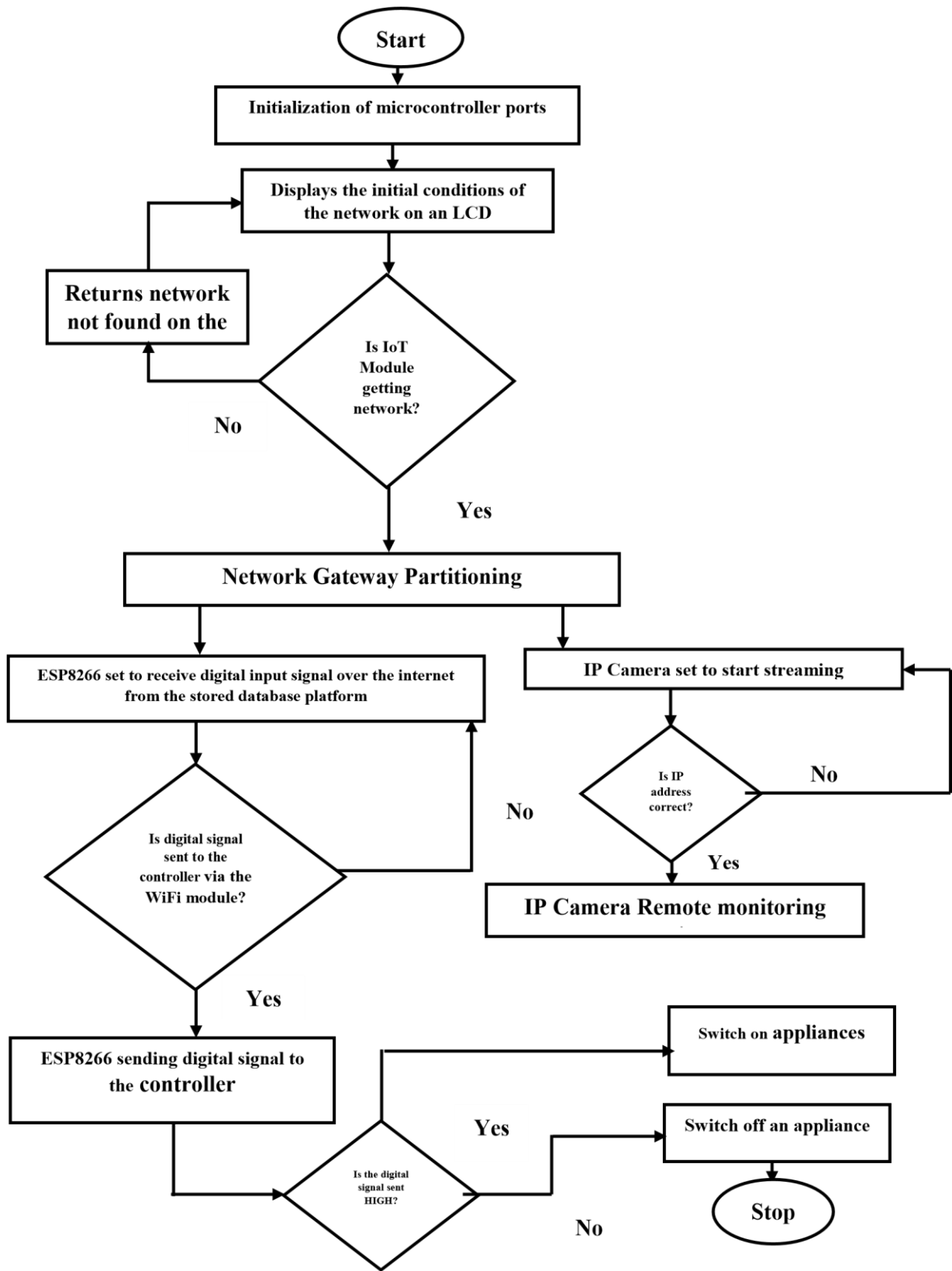

Figure 3.3: System Flowchart of the Smart Home Automation Unit

The automatic transfer system creates the platform for power to be automatically transferred to all the connected loads within the estate. The system scans through the phases via the three ADCs and switches according to the coded priorities. For instance, if there is power in the public utility phase, it quickly checks the voltage level whether it falls within the acceptable range. And if the voltage is within the allowable range, it ignores other sources and switches to the public utility. But if there is power on the public utility but the voltage falls out of allowable range, it ignores the public utility phase. Then it automatically moves to Renewable energy phase to check voltage level. If it is within the allowable range, it transfers power to the estate. But if the battery of the renewable energy is very low that makes the output voltage to be less than the acceptable range, it ignores the renewable energy phase and then moves to the portable generator phase. Before it checks the voltage level, it first starts the electronic choke portable generator automatically. All these processes are summarized in figure .3.4.

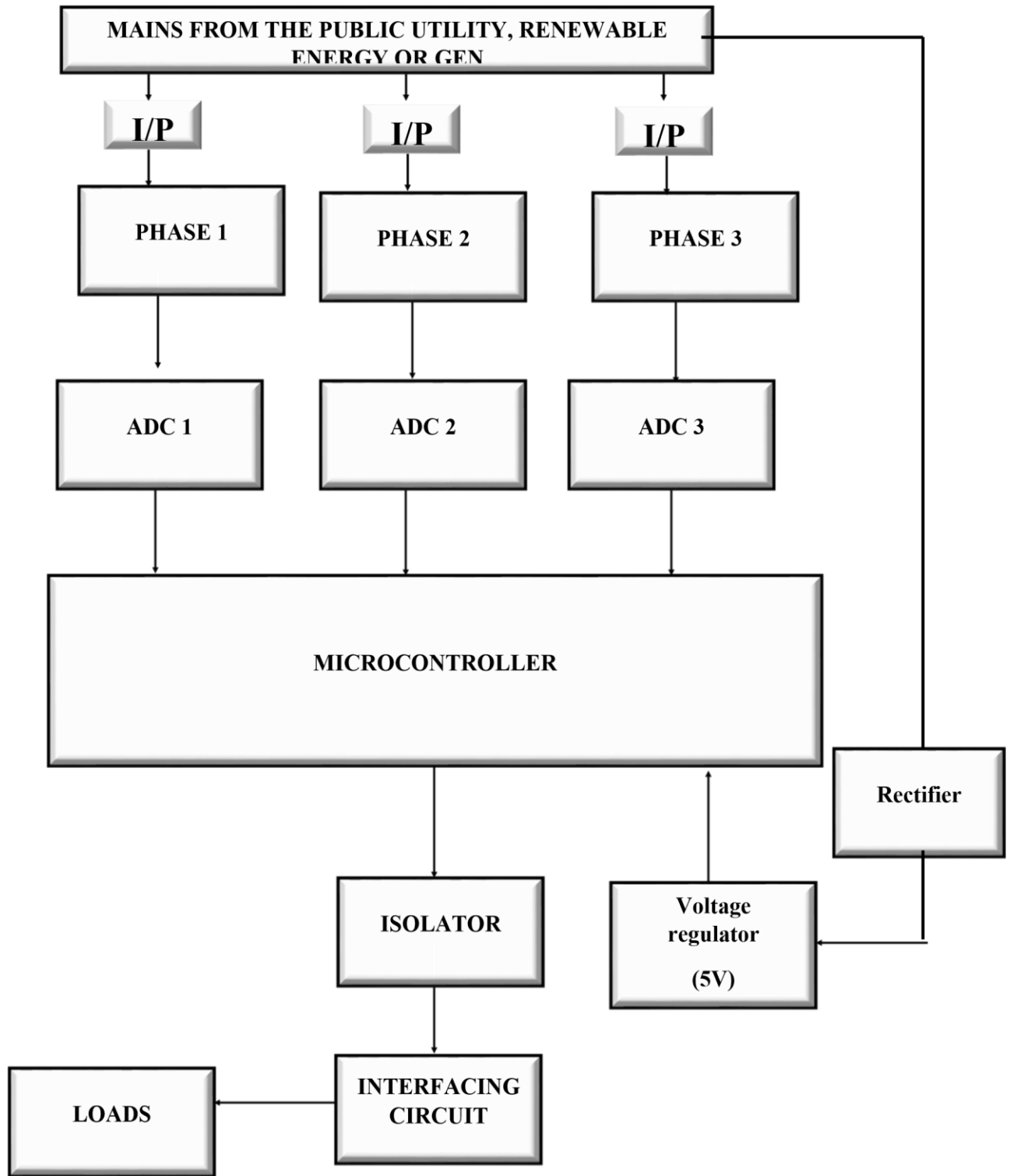

Fig.3.4: Block Diagram of Automatic Transfer System

Figure 3.5 depicts the public utility flow diagram which has the highest priority because its cost of operation is less expensive compared to the others. Whenever there is power restoration from the public

utility, the system switches to it and shuts down the portable generator if it was in use before the power restoration. And if it was the Renewable energy system that was on before the restoration of power from the public utility, it shuts down the renewable energy and allows it to be charging via the solar panels.

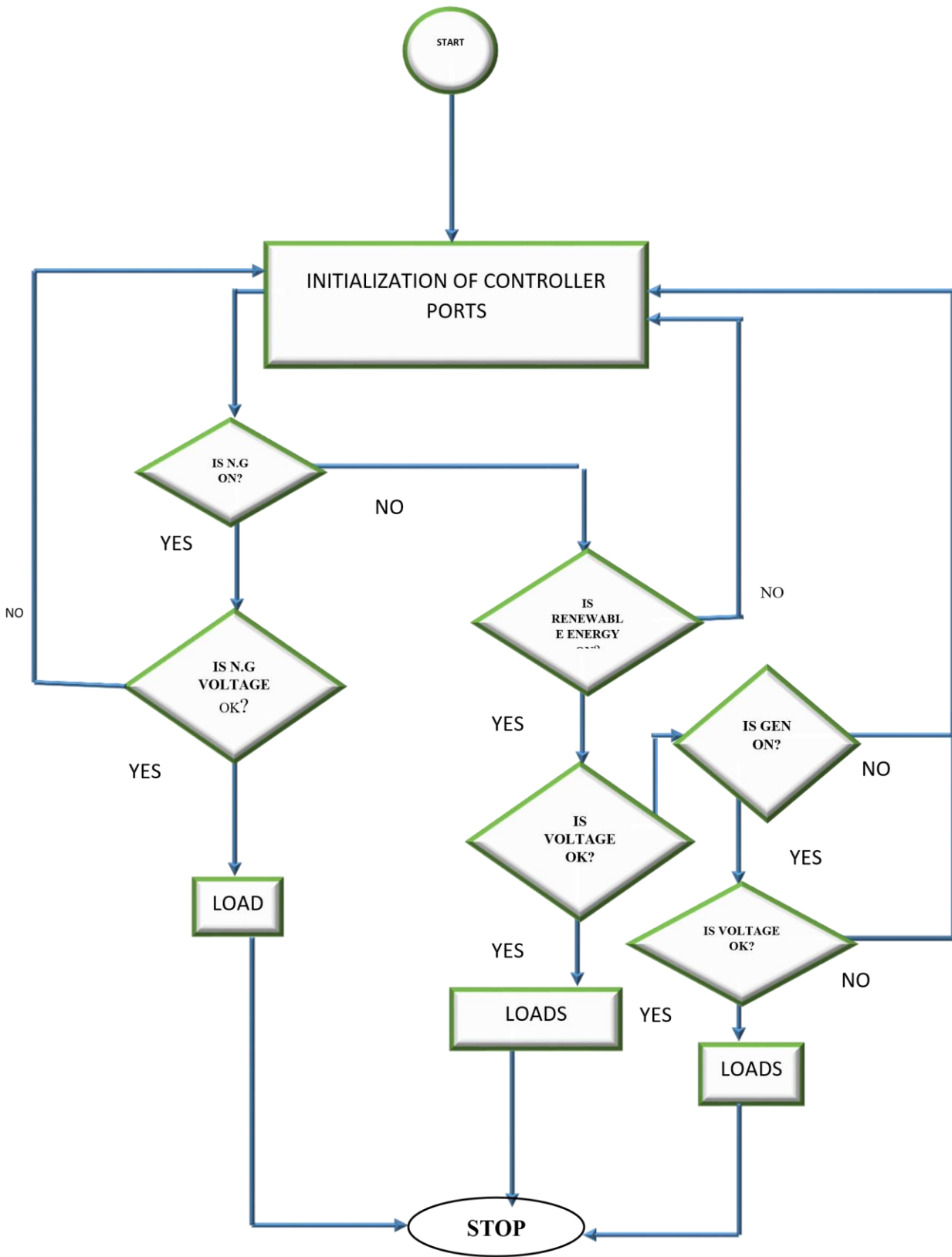

Figure. 3.5 The flow Diagram of the Automatic Transfer System

The GSM module was interfaced with the Arduino chip and Programmed in Arduino C and some attention commands (AT). A functional SIM card was inserted in the SIM900A module and then connected to the Arduino Chip for an automatic mobile SMS messenger to the security personnel. The Receiver terminal (Rx) of the SIM900A was connected to the Transmitter terminal (Tx) of the Arduino chip and the Transmitter terminal (Tx) of the SIM900A is connected to the Receiver terminal (Rx) of the Arduino chip. Arduino C ++ was used as the programming language for proper communications between the SIM900A and Arduino chip. This small system has a keypad with each key dedicated to a particular security alert when pressed. The block diagram is represented in figure 3.6.

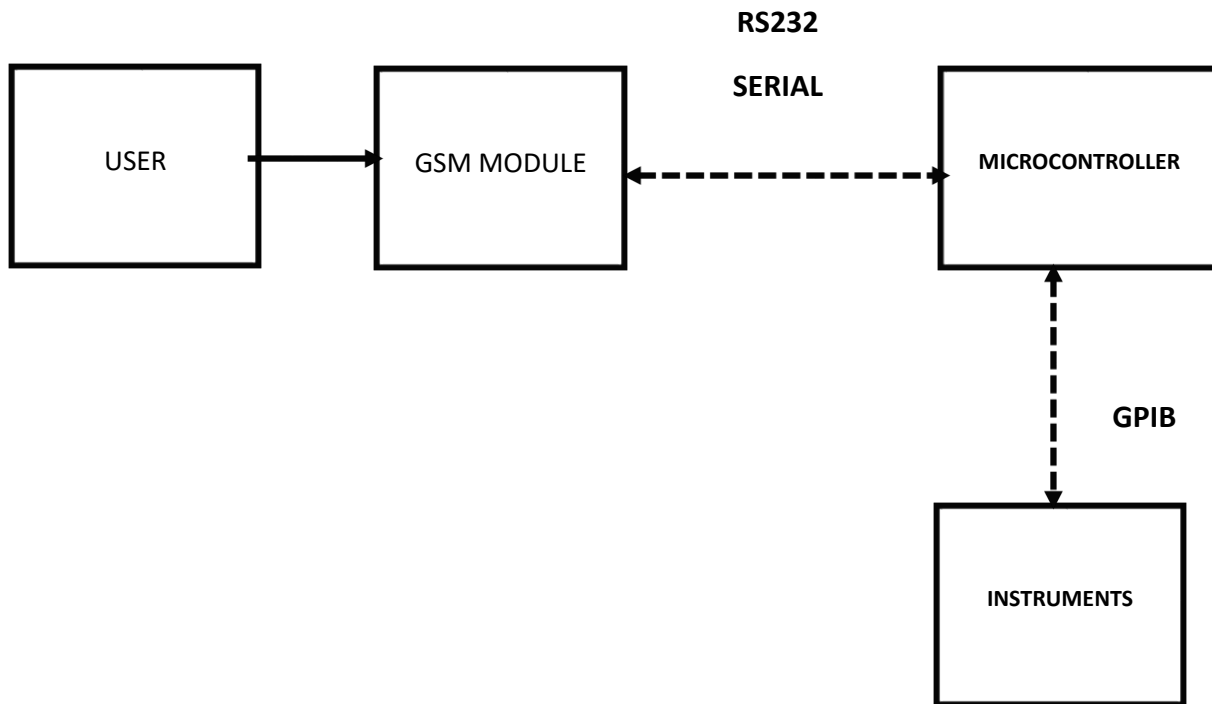

Figure. 3.6: The Block Diagram of A GSM Module Data Transmission

The block diagram for the energy management system is represented in figure 3.7. It comprises the light dependent resistor, the ac diode, fixed resistor and the ac triode. There were three sensing units which represented three different lightings within the estate. It could have more than that depending on the number of outside lights needed. The light sensor was the main part of this sub-system since it determines the current flow, which triggers the gate of the Triac for current to freely flow. The Triac is a high voltage discrete component that can handle up to 700V and this is why it is used here for switching the smart street lights.

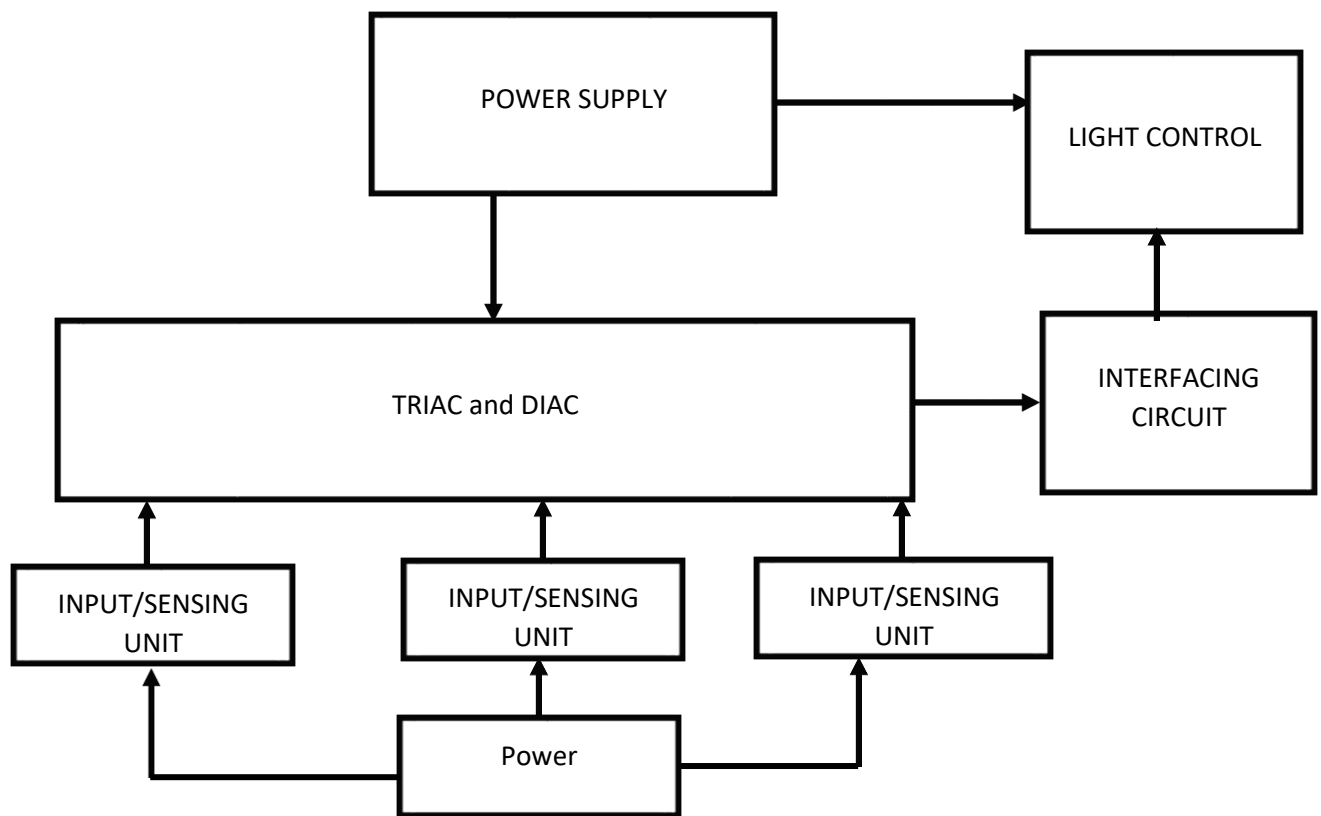

Figure. 3.7: The Block Diagram of Smart Street Light

Another feature to this system is a smart water level monitor and controller. The unique idea behind this feature is that it is purely contactless in measuring the distance between the transceiver and fluid in the overhead tank. As said before, a short ultrasonic pulse is transmitted and the time traveled for the

pulse to move from the transceiver to liquid and back to the transceiver. Ultrasonic pulse will bounce from liquid level because the change of density of ultrasonic pulse travel medium (ultrasonic pulse first travels through air and bounces off liquid with higher density than air). Because water has a higher density, the majority of the pulse would bounce off.

Apart from using an ultrasonic sensor, copper wires (electrodes) can also be used in designing a smart water level monitor and controller. The electrodes act as a gate for biasing the transistors connected to the Microcontroller. The microcontroller monitors the level of water based on the height of water in the tank and when the three electrodes are in contact with water, it automatically trips off the Sumo, which means the tank is full. Likewise, if the water level drops to normal, causing two electrodes to disengage from the water, the controller switches on the Sumo again. The whole process is repeated all over again and again. And as long as there is a power supply in the estate, the system keeps a constant supply of water to the estate. Figure .3.8 shows how the block diagram of the automatic water pump system.

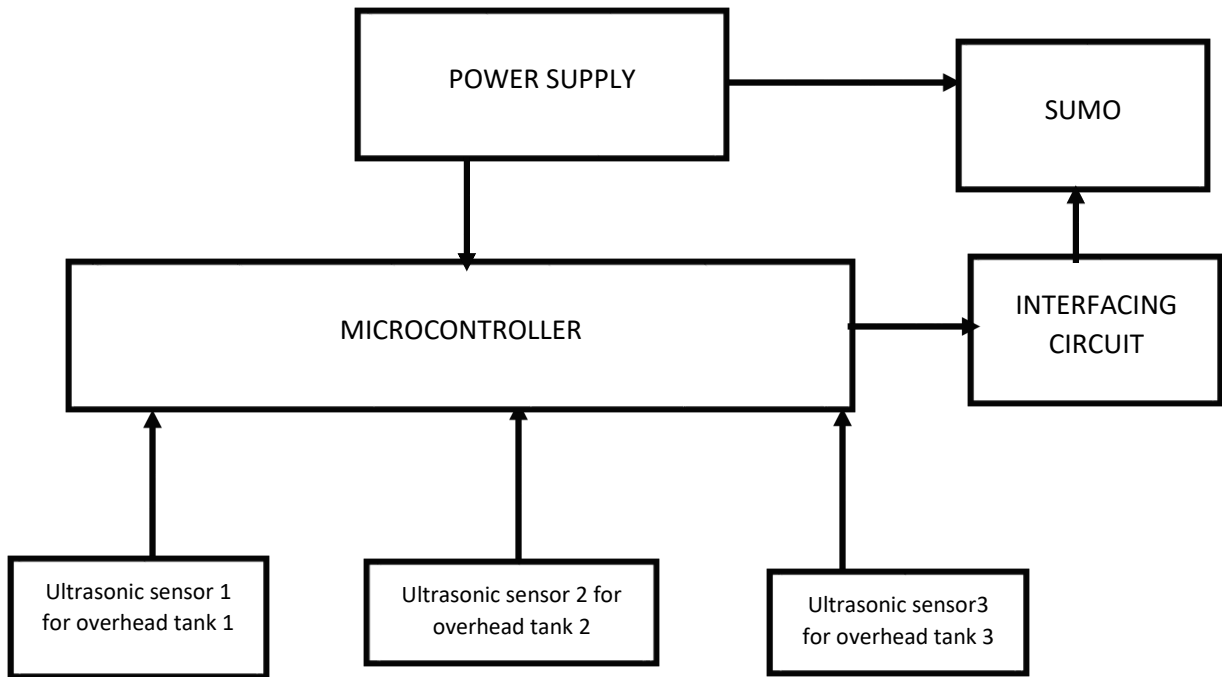

Figure. 3.8: The Block Diagram of a Smart Water Level Monitor and Controller

In the light of technology advancement, the sub-system in figure .3.8 shows the block diagram of wireless control of electrical appliances. With this system, an electronic choke portable generator can be started remotely. There are two main technologies necessary to achieve this, which are the Global System for Mobile Communication (GSM) and Dual Tone Multi Frequency (DTMF) technologies.

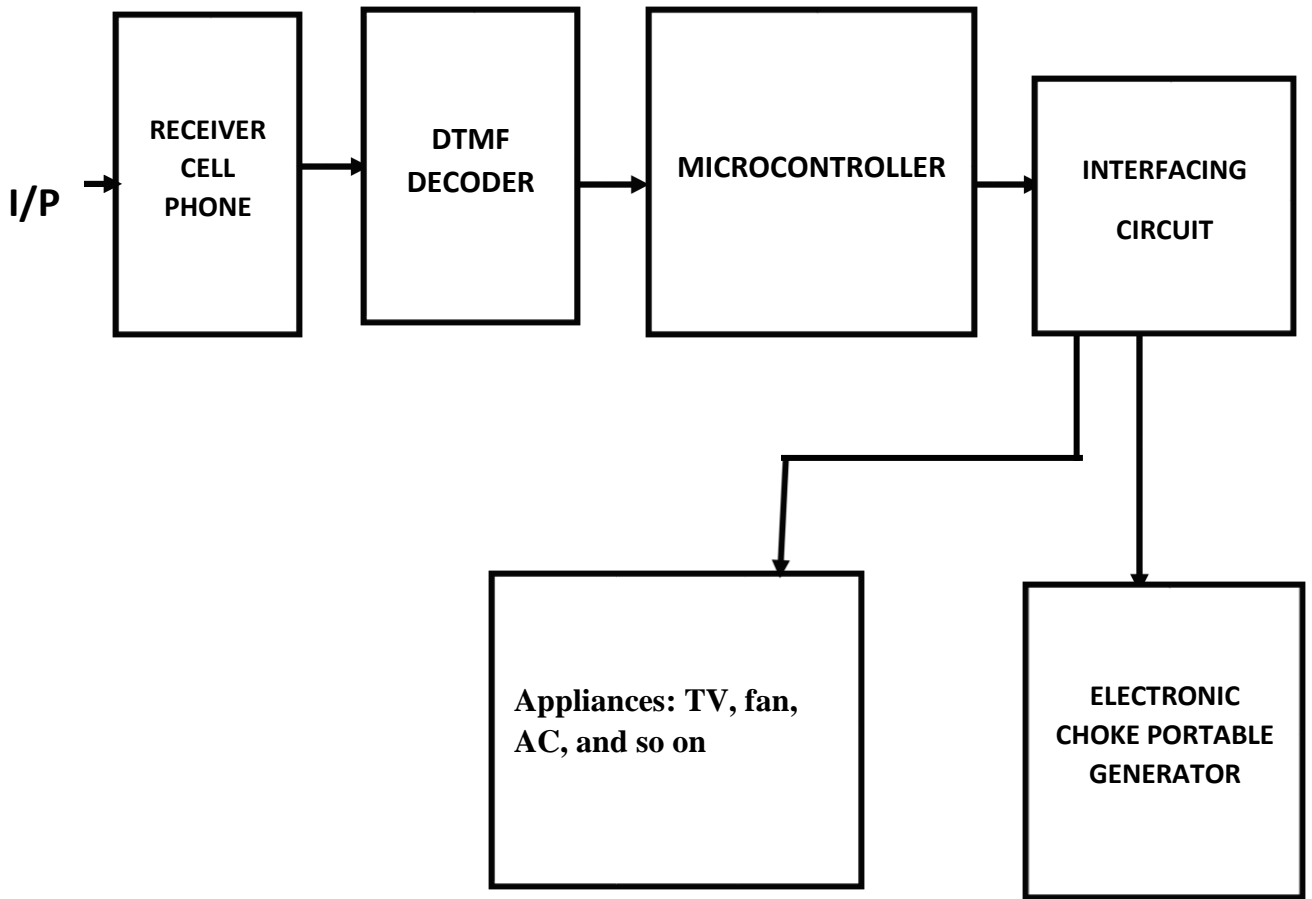
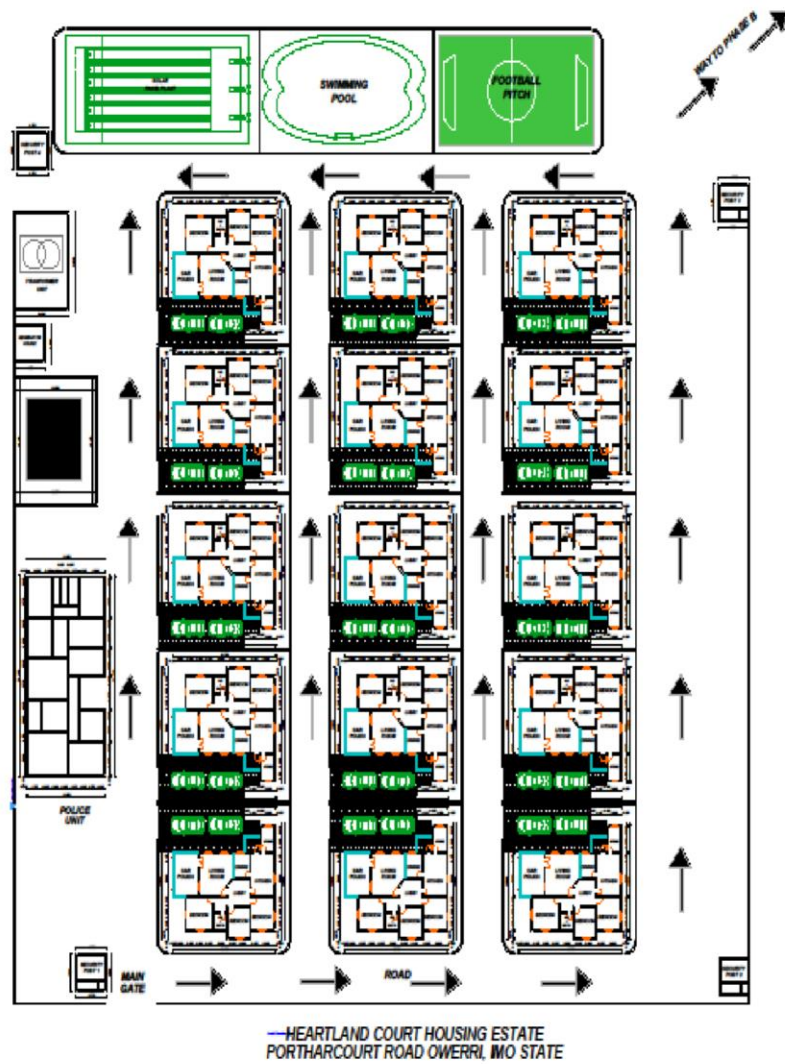

Figure 3.9 Block Diagram of DTMF Decoder

### **3.4 System Design**

Before the commencement of the design, a site plan of the estate was drawn using an Archi CAD software in order to have the proper orientation or trajectories of the estate. This would help in taking measurements in terms signal flow and avoidance of any possible obstacles within the estate. Heartland Court Housing Estate, Portharcourt road, Owerri, Imo State was used as the case study as shown in Figure .3.10. Working with parametric objects, ArchiCAD allows the user to create a "virtual building" with virtual structural elements like walls, slabs, roofs, doors, windows and furniture. ARCHICAD also allows the user to work with either a 2D or 3D representation on the screen.



**Plate 3.1: The Estate Site Plan Drawn Using an ArchiCAD Software**

### 3.4.1 Printed Circuit Board Design used in assembling the electronic components

Figures 3.11 and 3.12 are the Printed Circuit Board (PCB) to assembly the components. This makes component placement very much easier and helps to avoid unnecessary connection or disconnections as the case may be.

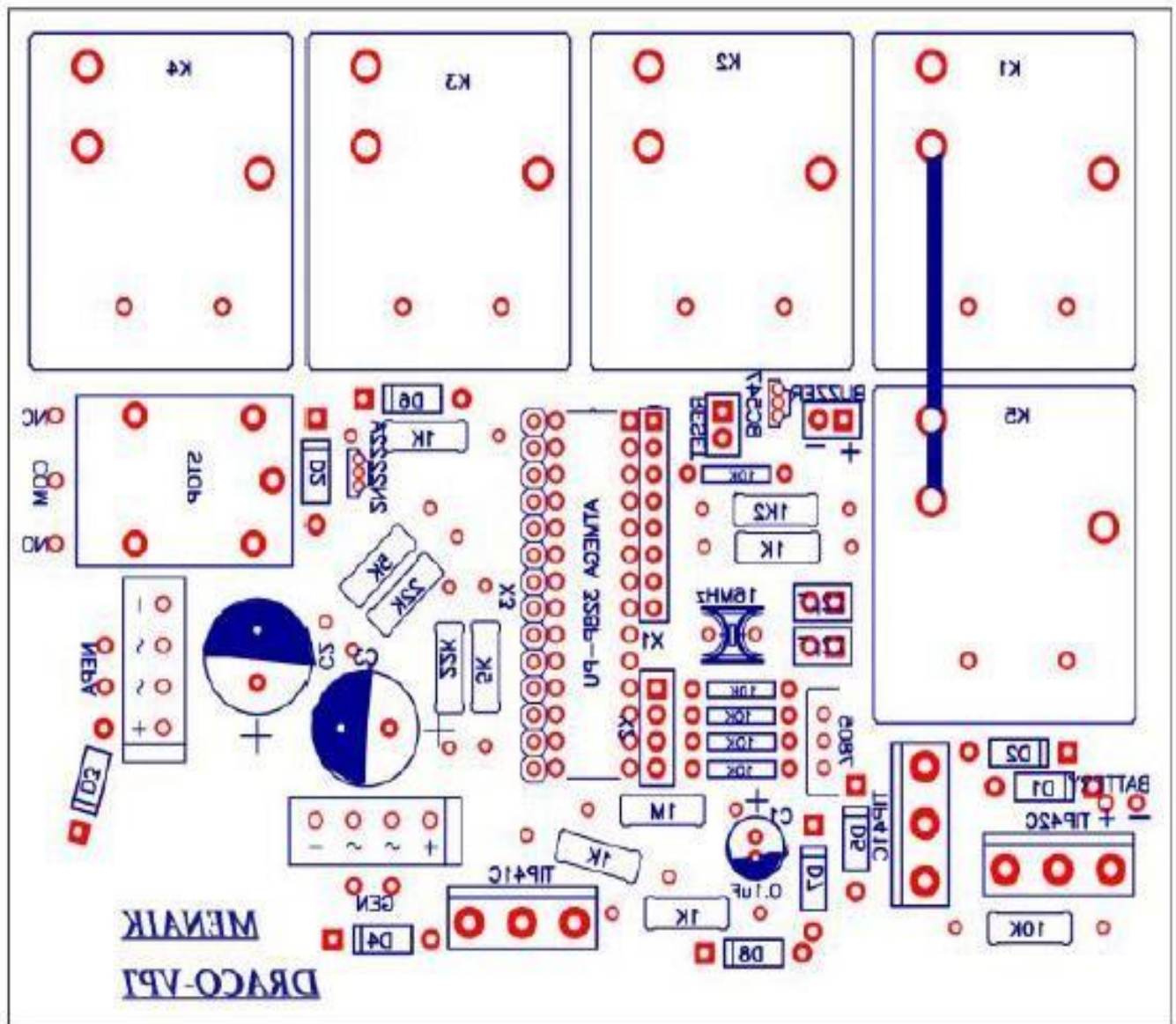

Figure 3.11: PCB Component Layout

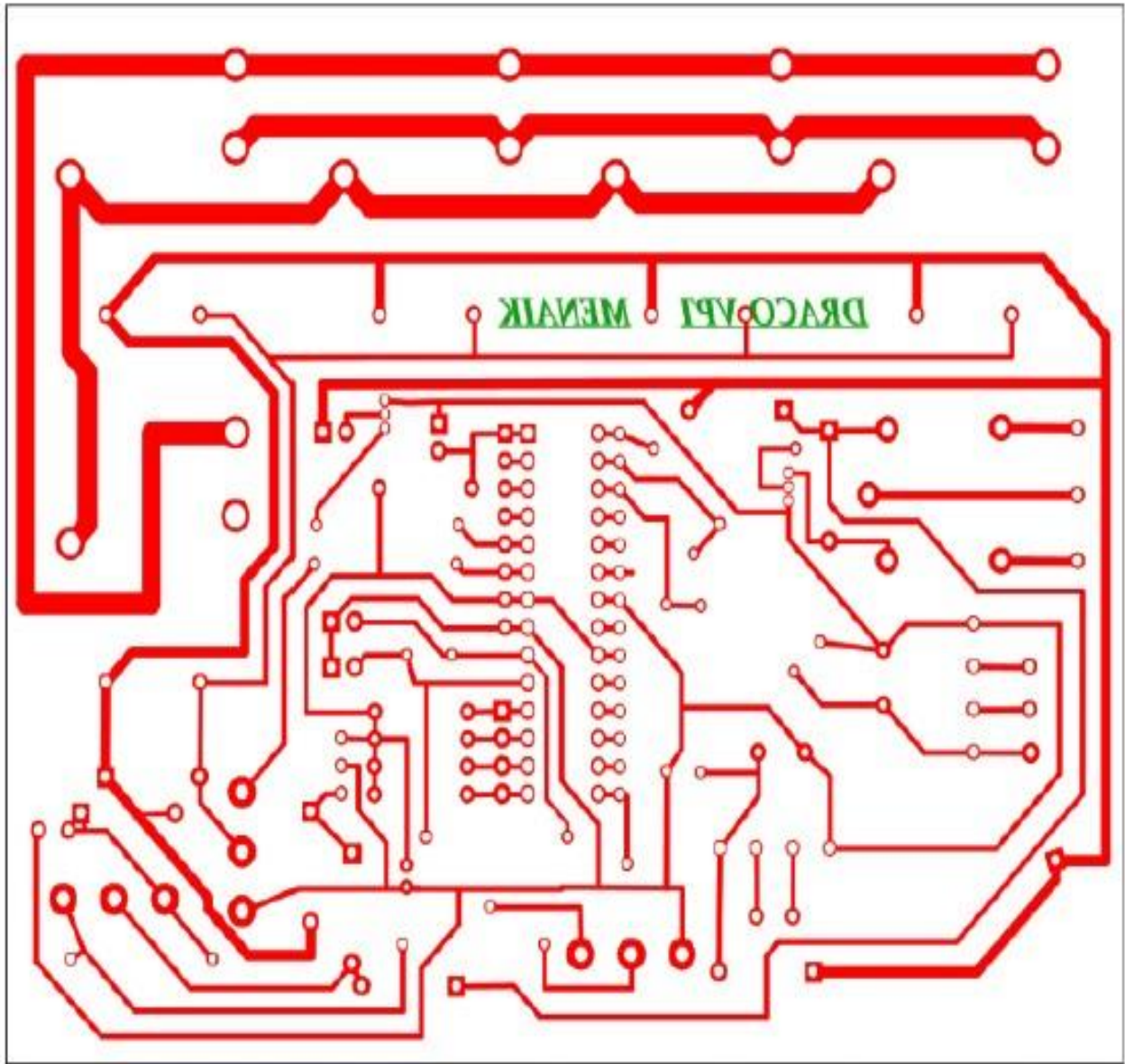

Figure 3.12: PCB Back Traces of Components

### 3.4.2 Design Specifications of ATS

The following components were used in the design of the automatic transfer system: Table 3.1: Design Specifications of the automatic transfer system

S/N	COMPONENT	QUANTITY
1	Rectifier diodes: 1N4007	4
2	Electrolytic capacitor (1000uF/25V)	1
3	Transistors (BC 547 npn)	1
4	Resistor (100K, 2W)	2
5	12V DC 30A relay	1
6	ATMEGA32 Microcontroller	1
7	Quartz crystal (12MHz)	1
8	Non polarized capacitor (30pF)	2
9	Variable resistor (20K)	1
10	16X2 LCD	1
11	Fixed resistor (1k)	1

### 3.4.3 System Circuit Design for the ATS

The system sub-circuit shown in figures s.3.13 comprises the circuit for the automatic transfer system (ATS) which takes care of keeping power uninterrupted provided the three power sources to the estate are functional. It also has surge protection against both under and over voltage protection. The Liquid Crystal Display (LCD) helps to display the particular phase of power in use.

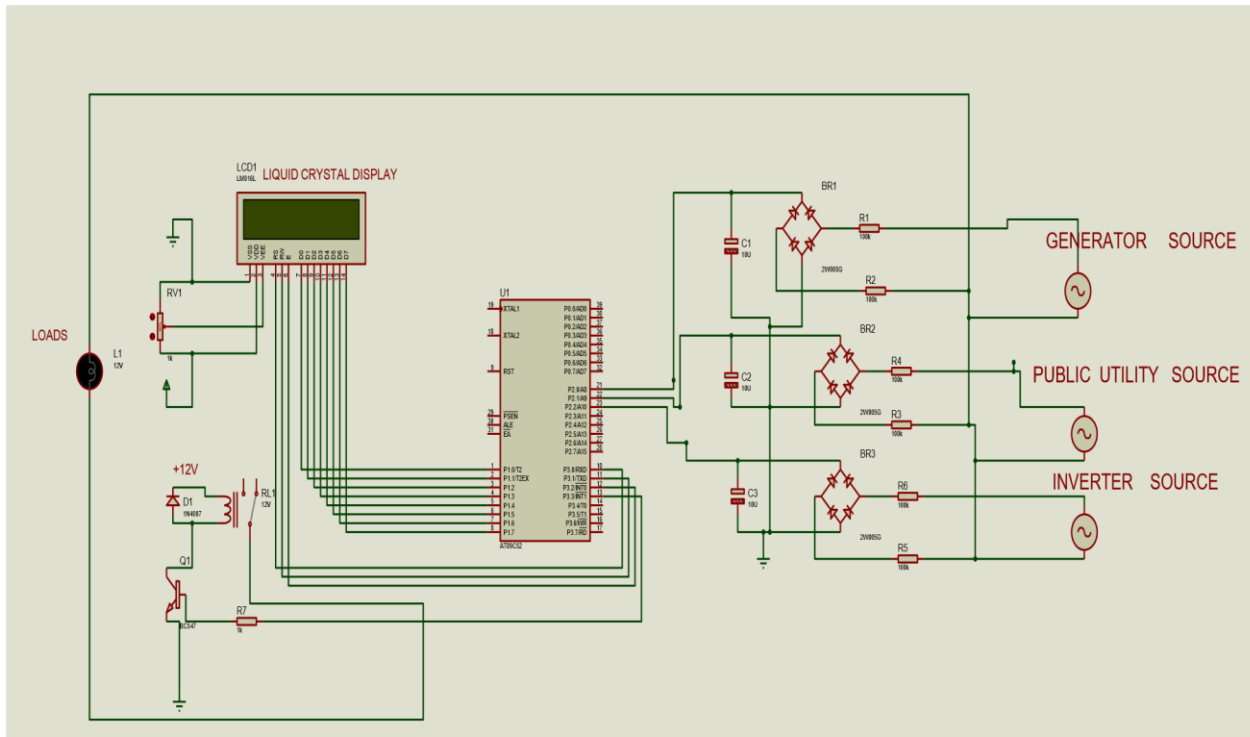

Figure 3.13: The Circuit Diagram of the ATS, Phase Selector with under/over voltage protection

### 3.4.4 Design Specifications of the Wearable Alert System

Table 3.2 shows the components used in the design of the Wearable Automatic Alert System: Table 3.2: Design Specifications of the Wearable Automatic Alert System

S/N	COMPONENT	QUANTITY
1	SIM900A GSM Module	1
2	Arduino chip (ATMEGA-328)	1
3	A keypad (2x2)	1
4	9V battery and its clip	1
5	12V DC 30A relay	1
7	Quartz crystal (16MHz)	1
8	Non polarized capacitor (22pF)	2

### 3.4.5 Circuit Design of the Wearable alert System

The wearable alert system has been designed in such a way that it can send different messages corresponding to the buttons pressed. From figure. 3.12, it can be seen that there are five buttons and each has a dedicated message to send if pressed. The idea here is that in case of attacks of any kind, at a particular gate in an estate that has more one gate, the security personnel at that gate one should be able to inform other colleagues at the other gates to intervene.

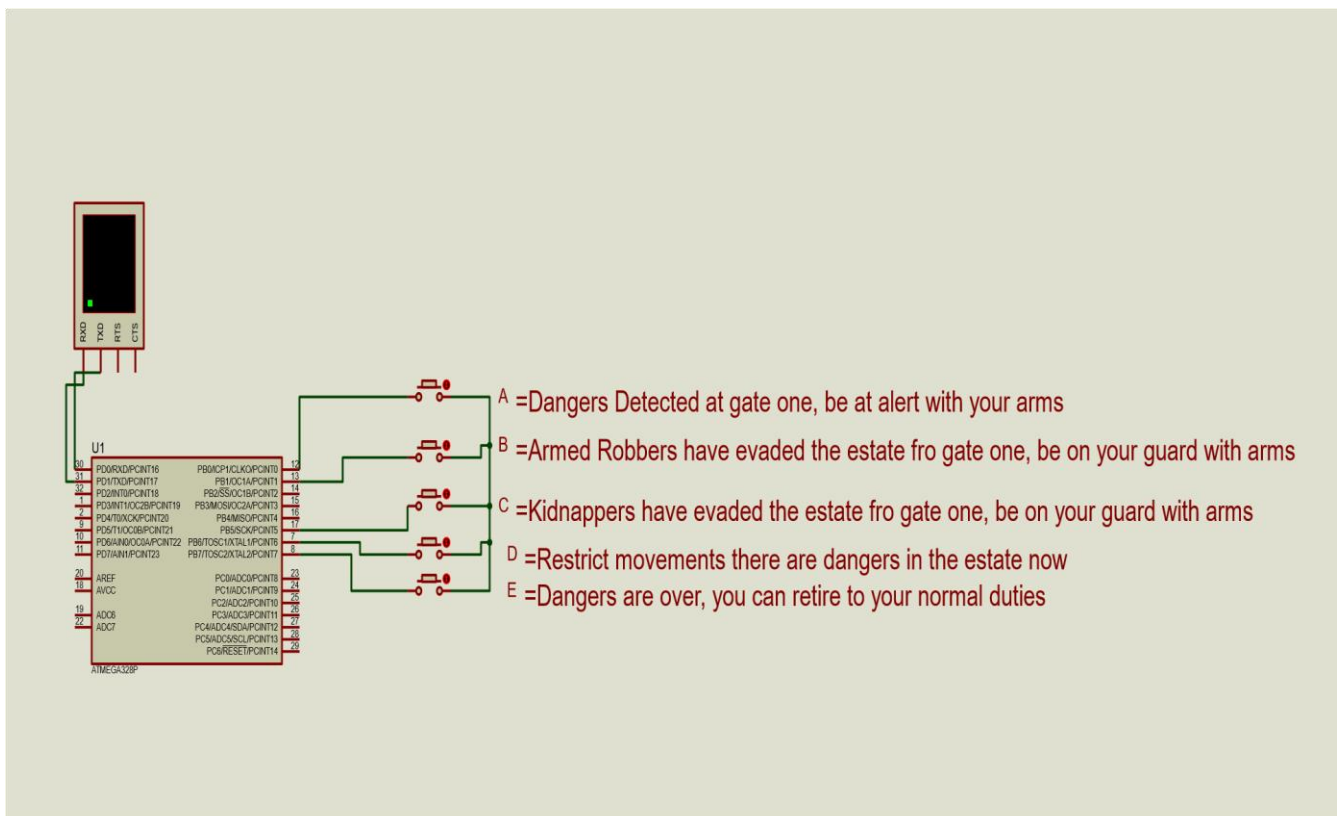

Figure 3.14: Circuit diagram of the Wearable Alert System

Whenever there are armed robbers in operations, it is not the best time to make calls, as that may cause the invaders to shoot the caller. But with this system, one could just pressed the corresponding button on the “wrist watch” like device around ones arm without allowing the robbers to know. Within ten seconds, the message gets to the nearest Security post within the estate. The mobile phone contacts of

outside security personnel such as Police, Army, Community Vigilante and other security bodies can also be incorporated.

### 3.4.6: Design Specifications for the Smart Street Light switch

Table 3.3 shows the components used in the design of the Smart Street Light switch Table 3.3: Design Specifications of the Smart Street Light switch

S/N	COMPONENT	QUANTITY
1	LDR	1
2	BT136 TRIAC	1
3	DIAC	1
4	9V battery and its clip	1
5	220k resistor	1

### 3.4.7 System Circuit Design of the Smart Street Light

It comprises the light dependent resistor, the ac diode, fixed resistor and the ac triode. There are three sensing units which represent three different lighting within the estate. It can have more than that depending on the number of outside lights needed. The light sensor is the main part of this sub-system since it determines the amount of voltage that triggers the gate of the Triac for current to freely flow.

Figure.3.15 shows the circuit design.

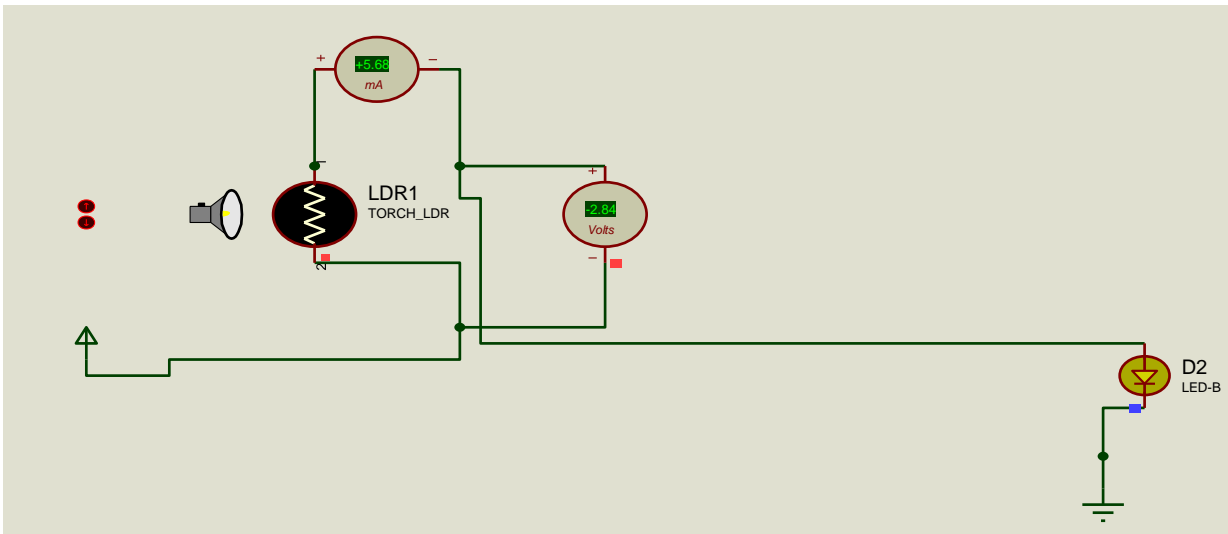

Figure 3.15: The simulated result of the Smart Street Light

### 3.4.8 Design Specifications for the Smart Water Level Monitor and Controller

Table 3.3 shows the components used in the design of the Smart Water Level Monitor and Controller

**Table 3.3: Design Specifications of the Smart Water Level Monitor and Controller**

S/N	COMPONENT	QUANTITY
1	ATMEGA328	1
2	HC-SR04 (Ultrasonic sensor)	1
3	BC 547	1
4	Quartz Crystal (16MHz)	1
5	22pF	2
6	220k resistor	1
7	Sumo (1.5 hP)	1

### 3.4.9 System Circuit Design for the Smart Water Level Monitor and Controller

Figure.3.16 is the circuit responsible for Uninterrupted Water Supply System (UWSS) to ensure that there is constant water supply to the chicks in the poultry without any form of human interface except in the event of maintenance or fault correction.

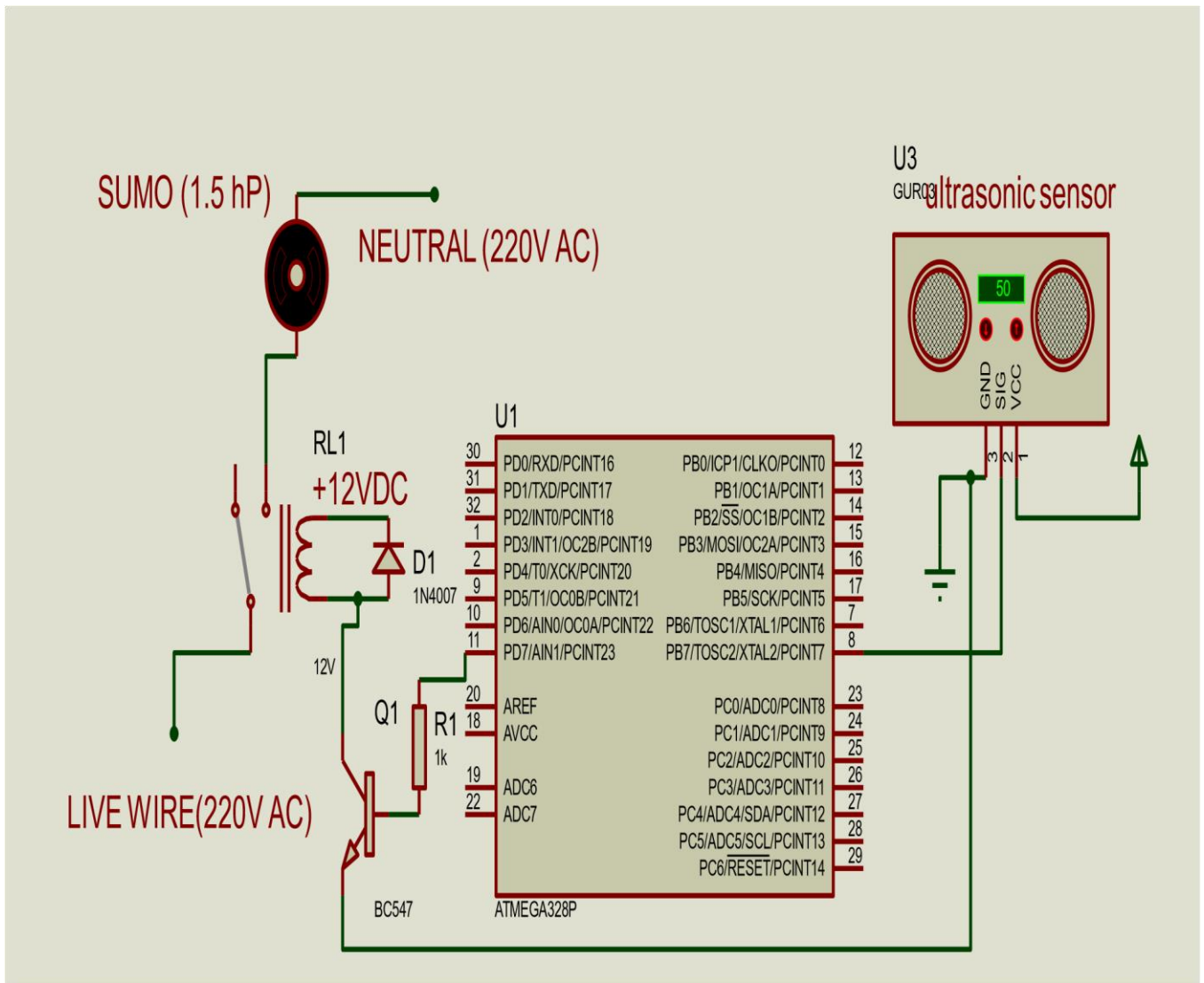

Figure 3.16: System Circuit Design of the Smart Water Level Monitor and Controller

### 3.5 Ultrasonic Sonar operation calculation and analysis

HC-SR04 module is used for contactless distance geometry from 2cm to 400cm by data sheet

specifications. It consists of a transceiver (ultrasonic transmitter and receiver) and a control circuit. The transmitter transmits short bursts which get reflected by the target and are picked up by the receiver. The time difference between the transmission and reception of ultrasonic signals is calculated thus:

The total time of flight of the ultrasonic burst from the sensor to the level of the liquid and back to the receiver is given by,

### **3.5.1 The Basic parameters are for the water level monitoring and control**

Let the total height of the overhead tank= $x$  (distance between the sensor and the floor);

Let the Current height (distance between the water inside and the sensor);

Let the distance measured by the system (Actual height of the water inside the bucket under the sensor);

The total height of the smart water reservoir (SWR) is about  $25\text{cm}=0.25\text{m}$ ;

This implies that;

$$x = y + z \tag{3.1}$$

Hence, the height of the water in the bucket to be measured is thus;

$$z = x - y \tag{3.2}$$

Given the speed of sound in air to be approximately  $340\text{ms}^{-1}$  or  $34000\text{cms}^{-1}$  (Seligman, 2018).

The instantaneous distance  $x$  is calculated as:

$$x = \frac{34000\text{cms}^{-1} \times dt}{2} = 170 \times t(\text{in metres}) \quad 3.3$$

Therefore, the instantaneous distance of water level in the bucket or any container (object) placed away from the sensor with respect to the wave time of flight was computed using equation (3.3).

### **3.6 System Circuit Design: Automation of Electrical Appliances**

Figure 3.15 is for the wireless control of electrical appliances within the estate such as the starting of an electronic choke portable generator via a mobile phone, automatic gate opener, and so on. The circuit was also capable of opening the gate to an estate automatically.

#### **3.6.1 System Circuit Design of Automation of Electrical Appliances using IoT for easy remote Load Reprogramming and scheduling**

The circuit diagram of the system involved the proper interfacing of the major modules such as the Arduino Module, ESP8266 (Nodemcu) module, Crystal Display Module (LCD) module, relay module, and other discrete components integration. The Nodemcu Controller was interfaced with a relay circuit for easy switching of AC-based loads using just a 5V signal from the General Purpose Input or Output pins of the Nodemcu. The connection was made using an NPN bipolar transistor which required a biasing base voltage of 1.5V for signal transition from the emitter to the collector of the transistor. The signal diode at the coil part of the relay was for polarity creation. And this also helped in avoiding erratic switching of signal.

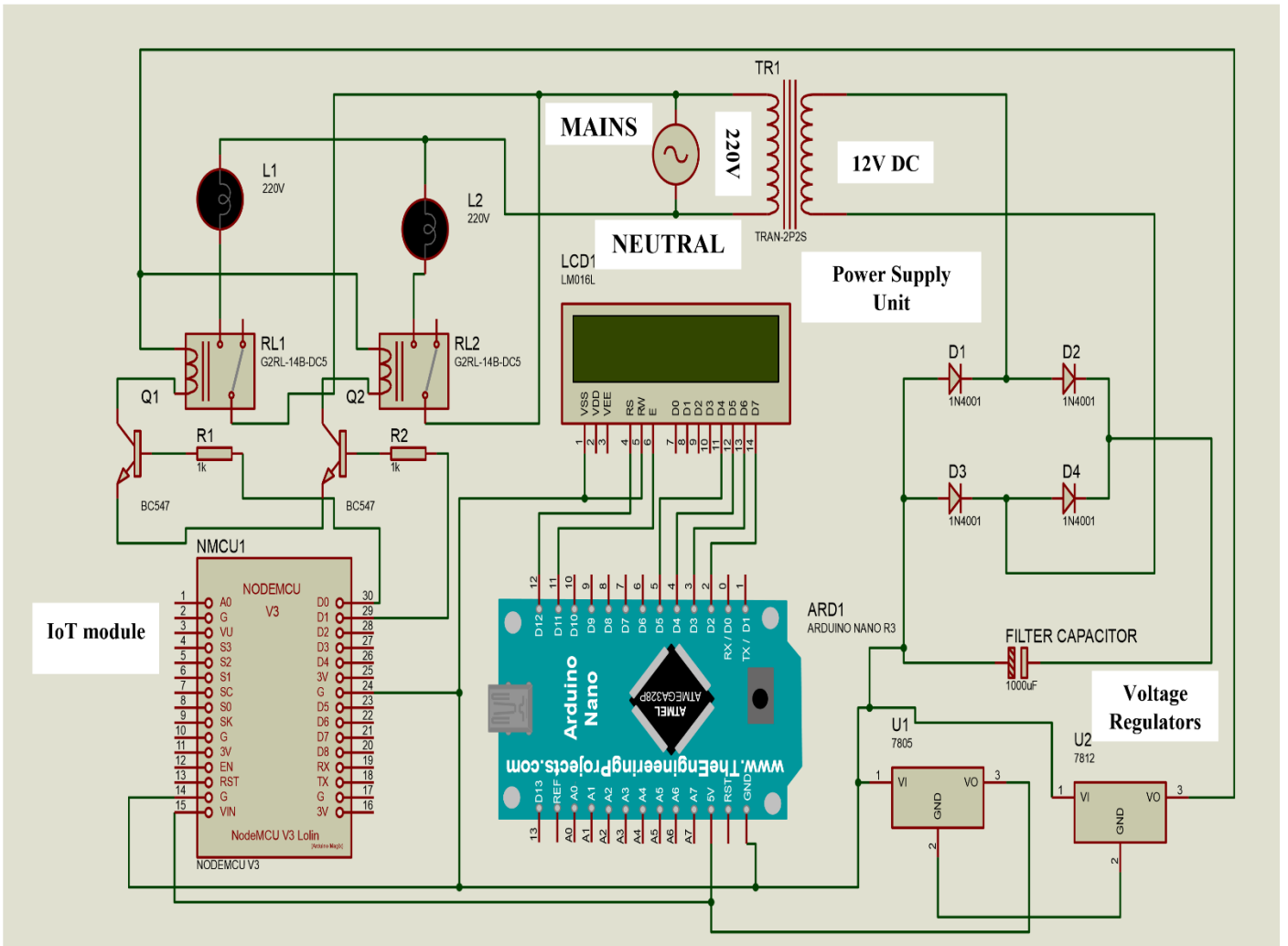

Figure 3.17: System circuit diagram for the IoT section and voltage monitoring

### 3.7 System Circuit Design of Automation of Electrical Appliances

Figure.3.18 is for the wireless control of electrical appliances within the estate such as starting of an electronic choke portable generator via a mobile phone, automatic gate opener, and so on. This circuit is also capable of opening the gate to an estate automatically.

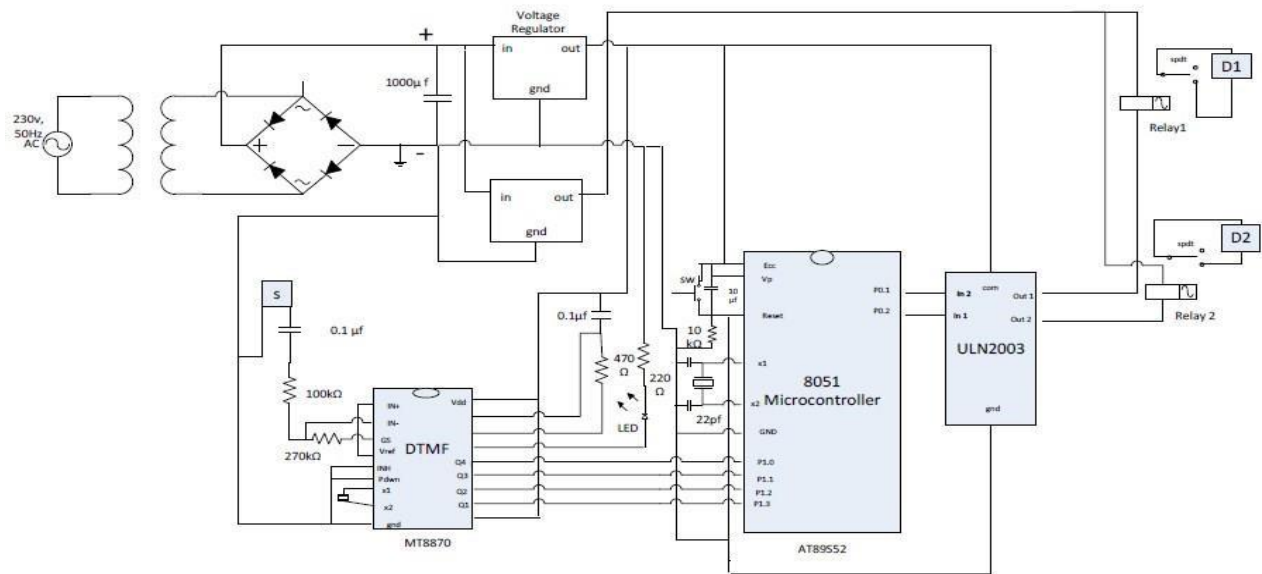

Figure 3.18: DTMF Circuit (DEBOLINA, 2015)

### 3.9 General design component values and associated calculations BC

547 common-emitter current-gain and the associated calculations:

From the data sheet of BC547 NPN transistor:

The following values were obtained;

- (i) Emitter current =  $I_E = -100\text{mA}$
- (ii) Base current =  $I_B = 20\text{mA}$
- (iii) Collector current =  $I_C = 100\text{mA}$
- (iv) Base-Emitter Voltage =  $V_{BE} = 0.7\text{V}$

Calculating the gain factor ( $\beta$ ) of the NPN transistor used:

Recall:

$$\text{Gain factor } (\beta) = \frac{I_C}{I_B} = \frac{100 \times 10^{-3}}{20 \times 10^{-3}} = 5$$

This implies that an input current to the emitter will have a gain factor of 5.

This is enough to switch the DC relay in the circuit.

Finding the relationship of collector current (output current) to emitter current (input current) which is known as  $\alpha$ . This is calculated thus;

$$\alpha = \frac{\Delta I_C}{\Delta I_E} \text{ or } = \frac{\beta}{\beta+1}$$

$$\text{Therefore } \alpha = \frac{\beta}{\beta+1} = \frac{5}{5+1} = \frac{5}{6} = 0.83$$

This implies that the input current at the emitter reached the collector at 83% output current to input current.

To find the accurate value for the biasing resistor connected at the base of the transistor, Figure 3.8

is used in accordance with the associated equations.

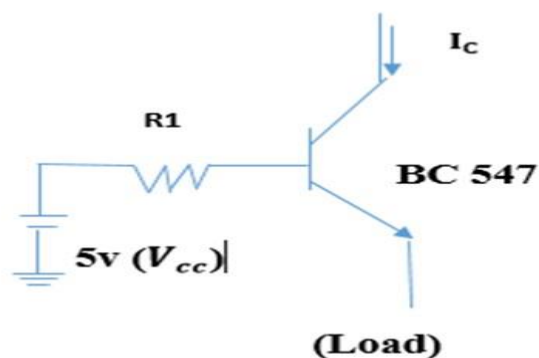

Figure 3.19: Relay Switching transistor (BC 547)

Recall ohm's law;

Base-emitter of BC 547 transistor = 0.7v (Datasheet). That is  $V_{BE} = 0.7v$

Voltage across  $R_1$  resistor =  $\frac{V_{CC} - V_{BE}}{I_B} = \frac{5v - 0.7v}{20 \times 10^{-3}} = \frac{4.3}{20 \times 10^{-3}} = \frac{4.3}{2} \times 10^2 = 2.15 \times 10^2 = 215\Omega$ . The

biasing resistor value is  $215\Omega$ , approximately  $220\Omega$  which is commonly available in the market.

### 3.10 Principle of Operation of the entire system

The operation of the system is quite simple. The system has three different power sources such as Public utility, Portable generator and Renewable energy. The public utility has the highest priority because its cost of operation is less expensive compared to the other two. Whenever there is power restoration from the public utility, the system switches to it and shuts down the portable generator if it was in use before the power restoration. And if it was the Renewable energy system that was on before the restoration of power from the public utility, it shuts down the renewable energy and allows it to be charging via the solar panels.

However, to control any appliance remotely, one needs to place on a dedicated phone number used in this work. And system has been configured in such a way that the receiver cell phone embedded in the main system picks incoming calls automatically. This makes it easy for one switch on or off any gadget within the estate by decoding the number pressed on the keypad of the embedded cell phone. With the help of Programming, every number on the keypad is dedicated to a particular function and are subject to changes if need be. There is also part of this system that is wearable for a quick SMS to the security personnel in the event of robbery attacks or other related vices within the estate. The Mobile Android IP-Webcam is mainly for remote monitoring of the gadgets under control. Lastly, the jamming subsystem, though it is already banned in some countries helps to interrupt communications amongst the perpetrators. The system is very simple to install and maintain within any highly recognized estate.

### 3.11 System Implementation

Figure 4.5 shows the entire sub-system in one form. This device is now a complete system that is capable of delivering the functions outlined in the problem statement. The results obtained in the test stages were presented in chapter four.



Figure 3.20: System Implementation

## RESULTS AND DISCUSSIONS

At the end of the design and implementation of this system prototype, this chapter presents the results obtained after several tests conducted in chapter three. The efficiencies of the existing automation systems and this design were also discussed.

### 4.1 RESULTS

#### 4.1.1 Test Result for the Smart Street Light Control

Figure 4.1 shows the graphical representation of the analog and digital signal results obtained. When the light sensor was exposed to light, its output value changed from  $100\text{K}\Omega$  to about  $3\Omega$  on a digital ohmmeter. Analog to digital conversion (ADC) technique was deployed to match the results based on a standard analog to digital metrics.

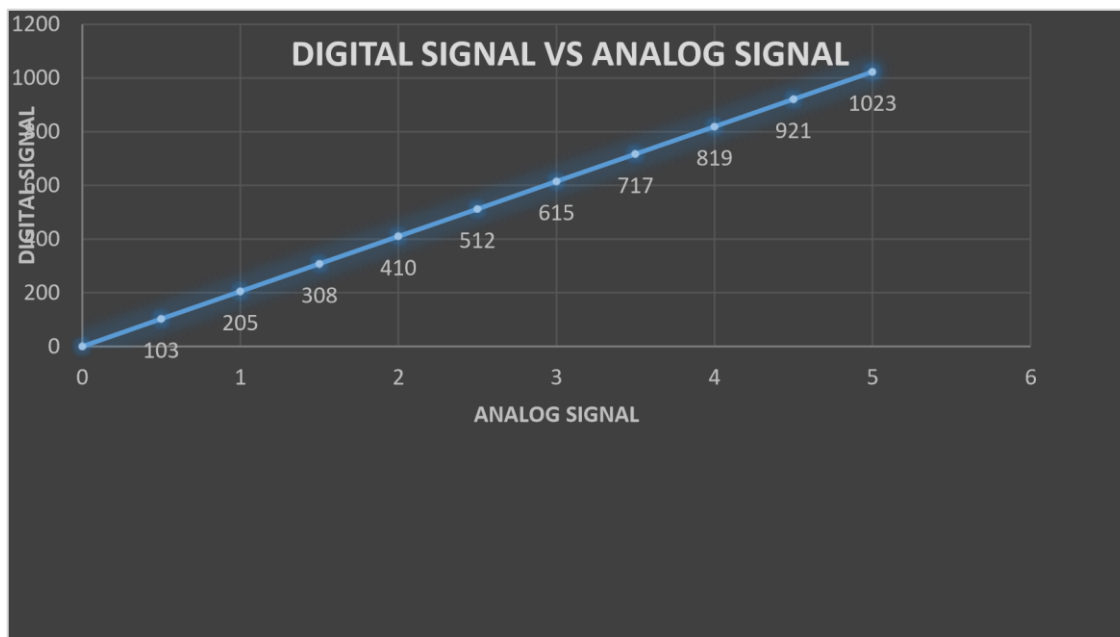

Plate 1 Graphical representation of the Analog vs Digital signal results

### 4.1.2 Test Result for the Automatic Transfer Switch

The system in less than 5ms changed over to the public utility and quickly turned off the portable generator set that was in used. The switching was done prior to checking if incoming g voltage was within the normal voltage range. Figure 4.1 shows the result obtained. The LCD was used as the scope to display the voltage level and the phase in use. Below 120v was used as under voltage cutoff while above 240V was used as base over voltage cutoff. Hence, whenever the voltage fluctuated to a level greater than 120V and less than or equal to 240V, power transfer to loads took place. Figure 4.2 shows the output from the results obtained.

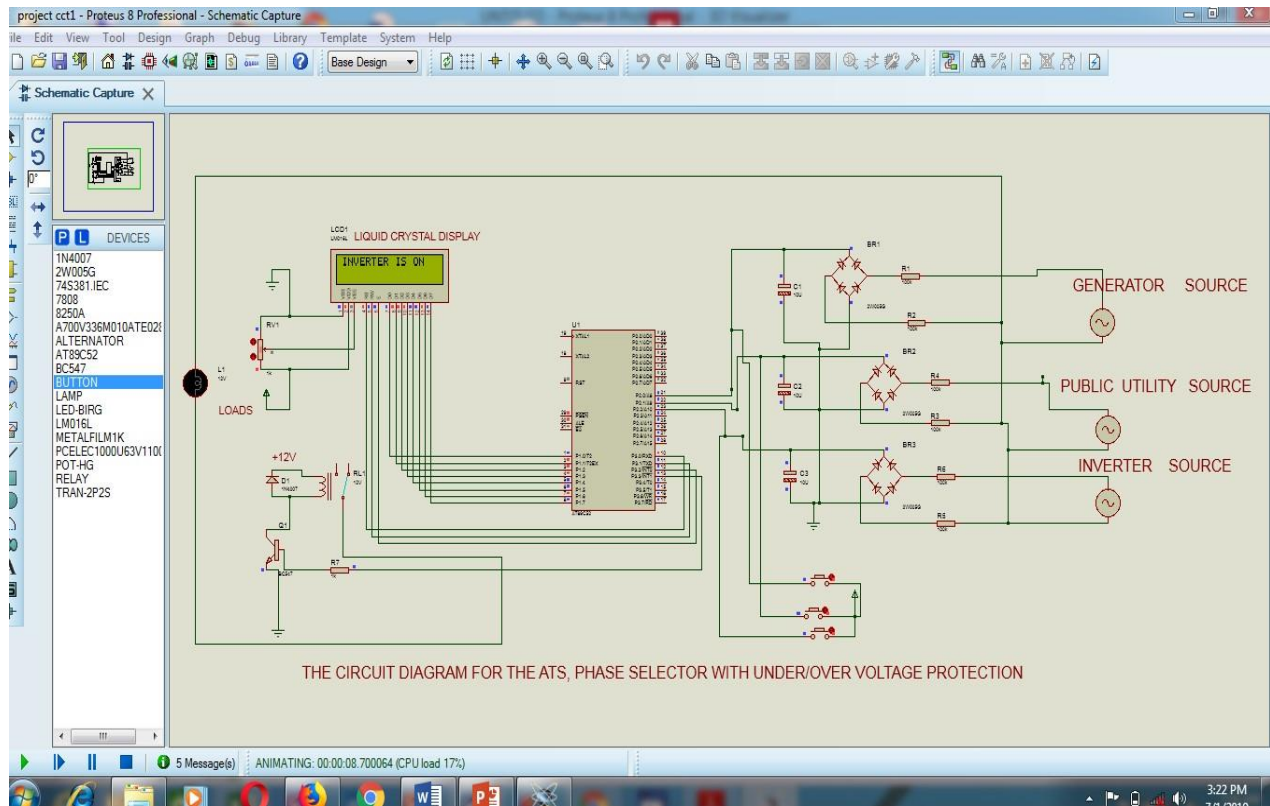

Plate 2: Normal Supply, Renewable energy and Portable generator output of Simulation

### **4.1.3 Test Results for the IoT Based Real-time Communication System**

After writing the Arduino sketch (code) and uploaded, it was monitored through the Arduino Serial Monitor located at the top right corner of the Arduino Integrated Development Environment (IDE). The Internet Protocol (IP) Address of the WiFi module (ESP8266/32) was detected. A browser such as Firefox, Opera mini, Chrome, Internet explorer and so on could be used to access the WiFi Module and be able to control the connected devices remotely. Figures 4.3a and 4.3b demonstrated the output webpage of the WiFi Module as displayed on the serial monitor on a PC. To access the devices online, the IP address of the ESP8266/32 was entered on the Search bar using any of the available browsers (Firefox, Opera mini, Chrome, Internet explorer). Three different loads were controlled in the design viz; the ceiling fan, the bulb and the socket-outlet. From the webpage displayed, the IP address of the WiFi Module was noted as 192.168.43.209 (private class C network).

## IOT BASED HOME AUTOMATION AND SURVEILLANCE SYSTEM

STUDENT: NWANKWOEKE, VICTOR OKECHUKWU

REG NO: 20174080738

OPTION: ELECTRONICS

Lead Supervisor: Engr. Prof. F.K. Opara

Supporting Supervisor: Engr. Dr. N. Nkwachukwu

Press on a designated button to turn ON/OFF a device of your choice in the house

REFRIGERATOR IS off

LED0 ON

LED0 OFF

PARLOUR CEILING FAN IS off

LED1 ON

LED1 OFF

ADD NEXT LOADS HERE...

Plate 2: Output of the IoT webpage (Off States of Loads)

## IOT BASED HOME AUTOMATION AND SURVEILLANCE SYSTEM

STUDENT: NWANKWOEKE, VICTOR OKECHUKWU

REG NO: 20174080738

OPTION: ELECTRONICS

Lead Supervisor: Engr. Prof. F.K. Opara

Supporting Supervisor: Engr. Dr. N. Nkwachukwu

Press on a designated button to turn ON/OFF a device of your choice in the house

REFRIGERATOR IS on

LED0 ON

LED0 OFF

PARLOUR CEILING FAN IS on

LED1 ON

LED1 OFF

ADD NEXT LOADS HERE...

#### 4.1.4 Logic Gate for the Water Level Monitor and Controller

There are two sensors for the overhead tank or reservoir. Its mode of operation obeys OR gate Rules

When there is at least a HIGH (water level gets to a calculated level) at the input port, there is an output.

Now, whenever both inputs are HIGH, there is output. There are two sensors, hence the OR gate must be a 2 input OR gate as shown in figure 4.1.

Take sensor at the output pipe = A

Sensor in the overhead tank = B

Then the output = C

Boolean Expression logic gate in figure. 4.4 is;  $C = A + B$

**Table 4.1: Truth table of the Logic Gate**

	B	A	C
	0	0	0
	0	1	1
	1	0	1
	1	1	1

## **CHAPTER FIVE**

### **CONCLUSION AND RECOMMENDATIONS**

#### **5.1 Conclusion**

The Design and implementation of a smart control system for improved estate management using GSM, IoT and DTMF technologies has been successfully developed and tested. The different hardware and software components used were properly described. Some constraints were encountered in the course of the implementation. The system is a fast and efficient approach for controlling the operations of major electrical gadgets within an estate. It aids the security agents in monitoring and securing the lives and property of the people living in therein. This equipment works in any housing estate with strong signal strength. The system is scalable, it can accommodate gadgets if need be.

## 5.2 Recommendations

Despite the versatility of this system, there is need to incorporate a Google map for accurate location of the gadgets under control and also create a database for each house for easy data retrieval.

## 5.3 Contributions to Knowledge

- i. A Smart Control System for Improved Estate Management is a novel to humanity.
- ii. This system can automatically transfer power to the loads by selecting the right phase based on the priorities of the available power sources and at the same time switch off portable generator or renewable energy in the event of power restoration or disruption from the public utility.
- iii. With this system, one can now remotely switch on or off an electronic choke portable generator from any location in the world as long as there is GSM network or Internet Access within the vicinity.
- iv. In many estates, whenever the Sumo or water pump is switched on to pump water, there is always a standby person who will help to switch the pump when the overhead tank is filled up and thereby making it seemly unavoidable to attend to other activities.
- v. It reduces wastages of water and electricity via automated switching on and off when necessary.
- vi. It provides enhanced and efficient security for the estate

## APPENDIX A

**Table A1: Activity Chart of the Research.**

S/N	ACTIVITY	PERIOD (WEEKS)
1	Literature Review	4
2	Feasibility Study	3
3	Market Survey	3
4	Design and Analysis	4
5	Simulation and Implementation	3
6	Validation and Testing	1

The estimated time of completion of the research = 18 weeks (4 months + two weeks) **Table A2: Bill of Engineering Materials**

S/N	Component	Quantity	Unit price	Total (₦)

<b>1</b>	ATmega328p Controller (Arduino UNO chip)	<b>1</b>	<b>7500</b>	<b>7500</b>
<b>3</b>	Crystal oscillator (16MHz)	<b>2</b>	<b>200</b>	<b>400</b>
<b>4</b>	ULN2003 relay driver	<b>3</b>	<b>550</b>	<b>1650</b>
<b>5</b>	Fixed resistor(220Ω)	<b>10</b>	<b>5</b>	<b>50</b>
<b>6</b>	22pF non polarized capacitor (2 pcs)	<b>2</b>	<b>30</b>	<b>60</b>
<b>7</b>	Signal diode (4148)	<b>2</b>	<b>30</b>	<b>60</b>
<b>8</b>	Rectifier diode (1N4007)	<b>4</b>	<b>40</b>	<b>160</b>
<b>9</b>	5V DC Relay module	<b>1</b>	<b>1600</b>	<b>1600</b>
<b>10</b>	Voltage regulator	<b>2</b>	<b>150</b>	<b>300</b>
<b>11</b>	Micro USB cable	<b>1</b>	<b>600</b>	<b>600</b>
<b>12</b>	Liquid Crystal Display (LCD)	<b>1</b>	<b>1500</b>	<b>1500</b>
<b>13</b>	Jumper wires (yards)	<b>2</b>	<b>800</b>	<b>1600</b>
<b>14</b>	Soldering lead (yards)	<b>5</b>	<b>100</b>	<b>500</b>
<b>15</b>	Vero board (dotted)	<b>1</b>	<b>300</b>	<b>300</b>
<b>16</b>	Electrolytic capacitor (1000μF)	<b>1</b>	<b>200</b>	<b>200</b>
<b>17</b>	IC Socket (28-pin)	<b>1</b>	<b>150</b>	<b>150</b>
<b>18</b>	12V Battery	<b>1</b>	<b>9800</b>	<b>9800</b>
<b>19</b>	6x6 adaptable box	<b>1</b>	<b>3500</b>	<b>3500</b>
<b>20</b>	A lamp-holder	<b>2</b>	<b>250</b>	<b>500</b>
<b>21</b>	Transistor (TIP41C)	<b>2</b>	<b>150</b>	<b>300</b>
<b>22</b>	Light Emitting Diode (LED)	<b>1</b>	<b>20</b>	<b>20</b>
<b>23</b>	Control switch (SPST)	<b>1</b>	<b>300</b>	<b>300</b>

<b>24</b>	Push to make button	<b>1</b>	<b>100</b>	<b>100</b>
<b>25</b>	6x6 wooden board	<b>1</b>	<b>400</b>	<b>400</b>
<b>26</b>	Screws	<b>4</b>	<b>50</b>	<b>200</b>
<b>27</b>	Flexible wire (yards)	<b>4</b>	<b>150</b>	<b>600</b>
<b>28</b>	Battery Connector	<b>1</b>	<b>600</b>	<b>600</b>
<b>29</b>	Spray paint	<b>1</b>	<b>800</b>	<b>800</b>
<b>30</b>	5mm Pipe	<b>1</b>	<b>2500</b>	<b>2500</b>
<b>31</b>	Digital Voltmeter	<b>1</b>	<b>2500</b>	<b>2500</b>
<b>32</b>	Ultrasonic Sensor	<b>3</b>	<b>6600</b>	<b>6600</b>
<b>33</b>	Energy saving bulbs (12V DC)	<b>2</b>	<b>1200</b>	<b>1200</b>
<b>TOTAL AMOUNT = <del>₦</del>56540.00</b> (Fifty six thousand five hundred and forty naira only)				

### Control Chart for Wearable Security Alert System

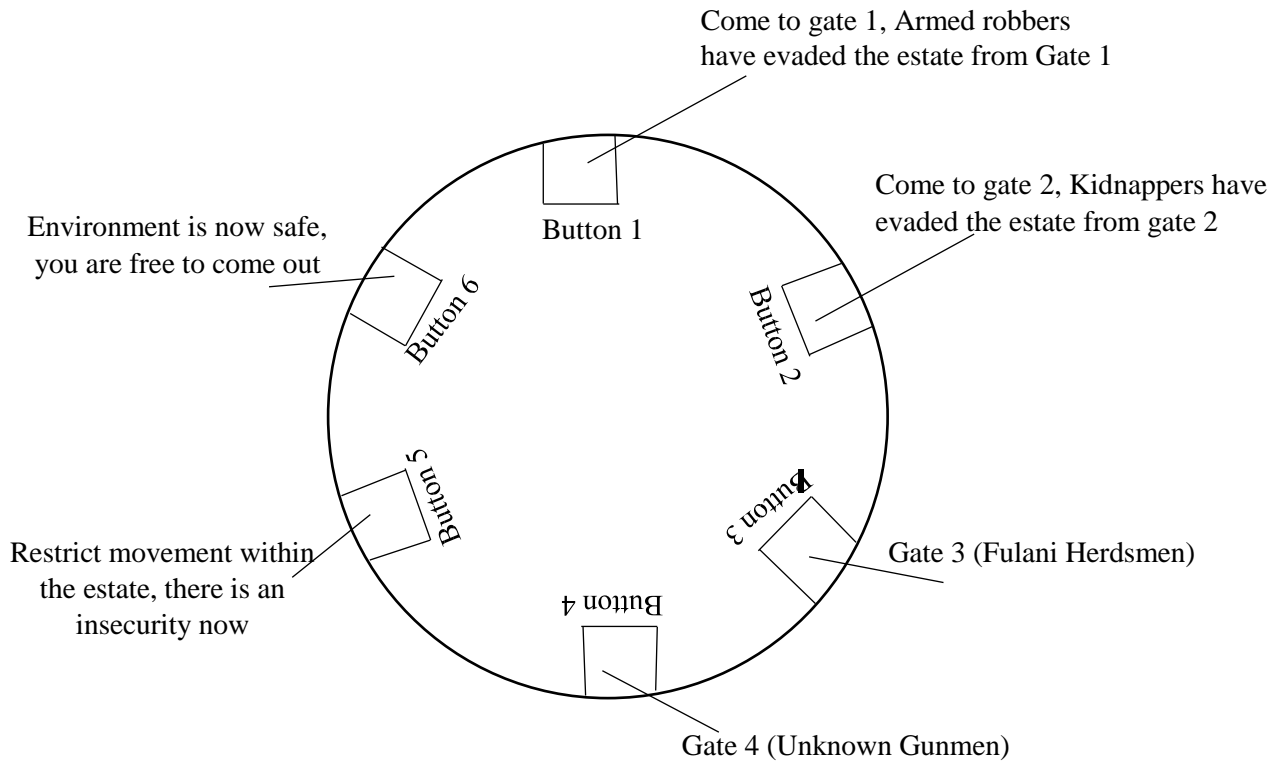

**Control Chart for Wearable Security Alert System**

**REFERENCES**

- Amrutha, A., Sugathan, S., & Abbare. (2015). Speech Recognition Based Wireless Automation of Home Loads- E Home. *International Journal of Engineering Science and Innovative Technology (IJESIT)*, 4(1), 179–184.
- Bhandari, R. (2020). *A Smart Home with NodeMCU using IOT*. 176(17), 30–32.
- Burton, Burpo, and G. (2018). *High-Performing Organizations Innovation in Cyberspace Colombia War-to-Peace 20th CBRNE Command*.
- Chavan et al.; 2017. (2017). Industrial Automation Control Using Raspberry Pi and Zigbee. *International Journal of Scientific Research in Science and Technology*, 3(4), 35–37.
- Chukwuchekwa, N. (2011). *Interpolation Technique in Multirate Digital Signal*. 3(2), 699–705.
- Debolina, A. (2015). *DTMF based home automation Title of the Project Report*. 1–42.
- FengYongjun. (2010). SIM900 AT Commands Manual V1.03. *Journal of Theoretical and Applied Information Technology*, 04, 5–10.
- <https://www.ldoceonline.com/dictionary/estate>. (2019). *Overview of estate* (pp. 1–2).
- Kantha & Priyanka, P. (2020). *Realization of an IoT System to Ensure Doorway Security by Integrating ESP32-CAM with Cloud Server*. 1235–1238.
- Kumar. (2017). *Economical Home Automation System using Arduino UNO*. 10(6), 1861–1866.
- Mamun, A. Al, & Hossain, M. A. (2020). Smart Home Automation System using Arduino and Android Application Smart Home Automation System using Arduino and Android Application. *Journal of Computer Science Engineering and Software Testing*, June.

- <https://doi.org/10.5281/zenodo.3816960>  
Muthukumar, M., Kannusamy, M., Kanagaraj, M. &, & Guruveswaran, A. (2019). *Bluetooth based Home Automation using Arduino*. 7(02), 1–5.
- Nwankwoeke Victor and Magbo Peter. (2016). Automation and Wireless Control of Electrical Appliances. *Final Year Project, Submitted to the Electrical and Electronic Department, Federal University of Technology of Owerri*, 1–44.
- Opara, F. K. (2003). *Computer and Data management with systems maintenance guides* (first edit).
- Prathapagiri, D., & Eethamakula, K. (2021). *Wi – Fi Door Lock System Using ESP32 CAM Based on IoT*. July.
- Raju Chandrani, & B. (2020). *Home Automation and Security System with Node MCU using Internet of Things*. June. <https://doi.org/10.1109/ViTECoN.2019.8899540>
- Sahana, H. S., Sandeep, V. S., Shwetha, R., Sowmya, J., & Krupa, K. S. (2017). *Office Automation System Using Internet of Things*. 1619–1622.
- Sehgal, T., & More, S. (2017). Home Automation using IOT and Mobile App. *International Research Journal of Engineering and Technology (IRJET)*, 694–698.
- Seligman, L. (2018). Speed of light. *Aviation Week and Space Technology*, 180(6), 48–49.  
[https://doi.org/10.1615/atoz.s.speed\\_of\\_light](https://doi.org/10.1615/atoz.s.speed_of_light)
- Shahdadpuri et al.; (2014). GSM Mobile Phone Jammer. *JSRD - International Journal for Scientific Research & Development*, 2(08), 154–158.
- Snehal Arun Khulape; Sakshi Rajendra Malage; Manasi Sudhir Patil; Arfa Aslam Bargir; Sagar V. Chavan. (2018). Home Automation Android Based GSM System. *International Journal of*

*Trend in Scientific Research and Development*, 2(6), 774–777. url:  
<http://www.ijtsrd.com/papers/ijtsrd18740.pdf%0ADirect> Link:  
<http://www.ijtsrd.com/engineering/computer-engineering/18740/home-automation-androidbased-gsm-system/miss-snehal-arun-khulape>

Snehal N. Bawane, P. Gautam, Ashish Dewase, V. Mishra, S. G. (2017). Automation of Irrigation System using Android Technology. *International Journal Of Engineering Science And Computing*, 7(3), 5580–5582.

T. Dobrowiecki, J. S. & T. (2005). *Identification of linear systems with nonlinear distortions*.

TADOJU, S. J. M. (2015). Bluetooth Remote Home Automation System using Android Application. *International Journal of Advanced Technology and Innovative Research (IJATIR)*, 07(10).

Taneja, H., Gupta, M., Kaushik, P., & Delhi, N. (2019). Home Automation Using Dtmf. *International Journal of Science Technology & Engineering*, 06(1), 184–187.  
<https://doi.org/10.15662/IJAREEIE.2019.0806003>

Venkateswara, P. (2015). RF Module Based Wireless Secured Home Automation System Using FPGA. *Journal of Theoretical and Applied Information Technology*, 77(2), 273–279.

Amrutha, A., Sugathan, S., & Abbare. (2015). Speech Recognition Based Wireless Automation of Home Loads- E Home. *International Journal of Engineering Science and Innovative Technology (IJESIT)*, 4(1), 179–184.

Bhandari, R. (2020). A Smart Home with NodeMCU using IOT. 176(17), 30–32.

Burton, Burpo, and G. (2018). High-Performing Organizations Innovation in Cyberspace Colombia War-to-Peace 20th CBRNE Command.

Chavan et al.; 2017. (2017). Industrial Automation Control Using Raspberry Pi and Zigbee.

International Journal of Scientific Research in Science and Technology, 3(4), 35–37.

Chukwuchekwa, N. (2011). Interpolation Technique in Multirate Digital Signal. 3(2), 699–705.

Debolina, A. (2015). DTMF Based Home Automation Title of the Project Report. 1–42.

FengYongjun. (2010). SIM900 AT Commands Manual V1.03. Journal of Theoretical and Applied Information Technology, 04, 5–10.

<https://www.ldoceonline.com/dictionary/estate>. (2019). Overview of estate (pp. 1–2).

Kantha & Priyanka, P. (2020). Realization of an IoT System to Ensure Doorway Security by Integrating ESP32-CAM with Cloud Server. 1235–1238.

Kumar. (2017). Economical Home Automation System using Arduino UNO. 10(6), 1861–1866.

Mamun, A. Al, & Hossain, M. A. (2020). Smart Home Automation System using Arduino and Android Application Smart Home Automation System using Arduino and Android Application. Journal of Computer Science Engineering and Software Testing, June. <https://doi.org/10.5281/zenodo.3816960>

Muthukumar, M., Kannusamy, M., Kanagaraj, M. &, & Guruveswaran, A. (2019). Bluetooth based Home Automation using Arduino. 7(02), 1–5.

Nwankwoeke Victor and Magbo Peter. (2016). Automation and Wireless Control of Electrical

Appliances. Final Year Project, Submitted to the Electrical and Electronic Department, Federal University of Technology of Owrri, 1–44.

Opara, F. K. (2003). Computer and Data management with systems maintenance guides (first edit).

Prathapagiri, D., & Eethamakula, K. (2021). Wi – Fi Door Lock System Using ESP32 CAM Based on IoT. July.

Raju Chandrani, & B. (2020). Home Automation and Security System with Node MCU using Internet of Things. June. <https://doi.org/10.1109/ViTECoN.2019.8899540>

Sahana, H. S., Sandeep, V. S., Shwetha, R., Sowmya, J., & Krupa, K. S. (2017). Office Automation System Using Internet of Things. 1619–1622.

Sehgal, T., & More, S. (2017). Home Automation using IOT and Mobile App. International Research Journal of Engineering and Technology (IRJET), 694–698.

Seligman, L. (2018). Speed of light. Aviation Week and Space Technology, 180(6), 48–49. [https://doi.org/10.1615/atoz.s.speed\\_of\\_light](https://doi.org/10.1615/atoz.s.speed_of_light)

Shahdadpuri et al.; (2014). GSM Mobile Phone Jammer. JSRD - International Journal for Scientific Research & Development, 2(08), 154–158.

Snehal Arun Khulape; Sakshi Rajendra Malage; Manasi Sudhir Patil; Arfa Aslam Bargir; Sagar V. Chavan. (2018). Home Automation Android-Based GSM System. International Journal of Trend in

Scientific Research and Development, 2(6), 774–777. url:

<http://www.ijtsrd.com/papers/ijtsrd18740.pdf%0ADirect> Link:

<http://www.ijtsrd.com/engineering/computer-engineering/18740/home-automation-android-basedgsm-system/miss-snehal-arun-khulape>

Snehal N. Bawane, P. Gautam, Ashish Dewase, V. Mishra, S. G. (2017). Automation of Irrigation System using Android Technology. *International Journal of Engineering Science And Computing*, 7(3), 5580–5582.

T. Dobrowiecki, J. S. & T. (2005). Identification of linear systems with nonlinear distortions.

TADOJU, S. J. M. (2015). Bluetooth Remote Home Automation System using Android Application.

*International Journal of Advanced Technology and Innovative Research (IJATIR)*, 07(10).

Taneja, H., Gupta, M., Kaushik, P., & Delhi, N. (2019). Home Automation Using Dtmf. *International Journal of Science Technology & Engineering*, 06(1), 184–187.

<https://doi.org/10.15662/IJAREEIE.2019.0806003>

Venkateswara, P. (2015). RF Module Based Wireless Secured Home Automation System Using FPGA.

*Journal of Theoretical and Applied Information Technology*, 77(2), 273–279.

## Appendix A: C ++ codes (for SMS security aid)

```
#include <SoftwareSerial.h>

SoftwareSerial mySerial(7,8);

//TX=PIN7
//RX=PIN8 char msg;
char call;

#define BUTTON1 9

#define BUTTON2 10

#define BUTTON3 11

#define  BUTTON4  12  #define
BUTTON5 13

int  button1state,button2state,button3state,button4state,button5state=0; void
setup()

{

  pinMode(BUTTON1,INPUT);    pinMode(BUTTON2,INPUT);
pinMode(BUTTON3,INPUT);    pinMode(BUTTON4,INPUT);
pinMode(BUTTON5,INPUT);

  mySerial.begin(9600); // Setting the baud rate of GSM Module

  Serial.begin(9600);// Setting the baud rate of Serial Monitor (Arduino)
```

```

Serial.println("press button");

}

void SendMessage1()

{

    mySerial.println("AT+CMGF=1"); //Sets the GSM Module in Text Mode delay(1000);
// Delay of 1000 milli seconds or 1 second

    mySerial.println("AT+CMGS=\"+2348069467459\"\\r"); // Replace x with mobile number
delay(1000);

    mySerial.println("Restrict Movements, Armmed Robbers have evaded the ESTATE via Gate 1, Stay
safe");// The SMS text you want to send
delay(100);

    mySerial.println((char)26);// ASCII code of CTRL+Z delay(7000);

    mySerial.println("AT+CMGF=1"); //Sets the GSM Module in Text Mode delay(1000);
// Delay of 1000 milli seconds or 1 second

    mySerial.println("AT+CMGS=\"+2348033377276\"\\r"); // Replace x with mobile number
delay(1000);

    mySerial.println("Message 1");// The SMS text you want to send delay(100);

    mySerial.println((char)26);// ASCII code of CTRL+Z delay(2000);

    mySerial.println("AT+CMGF=1"); //Sets the GSM Module in Text Mode delay(1000);
// Delay of 1000 milli seconds or 1 second

```

```
mySerial.println("AT+CMGS=\"+2348108178186\"\\r"); // Replace x with mobile number
delay(1000);
```

```
mySerial.println("Restrict Movements, Armmed Robbers have evaded the ESTATE via Gate 1, Stay
safe");// The SMS text you want to send delay(100);
```

```
mySerial.println((char)26);// ASCII code of CTRL+Z delay(1000);
```

```
}
```

```
void SendMessage2()
```

```
{
```

```
mySerial.println("AT+CMGF=1"); //Sets the GSM Module in Text Mode delay(1000);
// Delay of 1000 milli seconds or 1 second
```

```
mySerial.println("AT+CMGS=\"+2348069467459\"\\r"); // Replace x with mobile number
delay(1000);
```

```
mySerial.println("Restrict Movements, unknown gunmen have evaded the ESTATE via Gate 1,
ASSIST IN ANY WAY YOU CAN");// The SMS text you want to send delay(100);
```

```
mySerial.println((char)26);// ASCII code of CTRL+Z delay(7000);
```

```
mySerial.println("AT+CMGF=1"); //Sets the GSM Module in Text Mode delay(1000);
// Delay of 1000 milli seconds or 1 second
```

```
mySerial.println("AT+CMGS=\"+2348033377276\"\\r"); // Replace x with mobile number
delay(1000);
```

```
mySerial.println("Restrict Movements, unknown gunmen have evaded the ESTATE via Gate 1,
ASSIST IN ANY WAY YOU CAN");// The SMS text you want to send delay(100);
```

```
mySerial.println((char)26);// ASCII code of CTRL+Z delay(2000);
```

```
mySerial.println("AT+CMGF=1"); //Sets the GSM Module in Text Mode delay(1000);
// Delay of 1000 milli seconds or 1 second
```

```
mySerial.println("AT+CMGS=\"+2348108178186\"\\r"); // Replace x with mobile number
delay(1000);
```

```
mySerial.println("Restrict Movements, unknown gunmen have evaded the ESTATE via Gate 1,
ASSIST IN ANY WAY YOU CAN");// The SMS text you want to send delay(100);
```

```
mySerial.println((char)26);// ASCII code of CTRL+Z delay(1000);
```

```
}
```

```
void SendMessage3()
```

```
{
```

```
mySerial.println("AT+CMGF=1"); //Sets the GSM Module in Text Mode
```

```

delay(1000); // Delay of 1000 milli seconds or 1 second

mySerial.println("AT+CMGS=\"+2348069467459\"\\r"); // Replace x with mobile number
delay(1000);

mySerial.println("Restrict Movements, HERDSMEN have evaded the ESTATE via Gate 1, ASSIST
IN ANY WAY YOU CAN");// The SMS text you want to send delay(100);

mySerial.println((char)26);// ASCII code of CTRL+Z delay(7000);

mySerial.println("AT+CMGF=1"); //Sets the GSM Module in Text Mode delay(1000);
// Delay of 1000 milli seconds or 1 second

mySerial.println("AT+CMGS=\"+2348033377276\"\\r"); // Replace x with mobile number
delay(1000);

mySerial.println("Restrict Movements, HERDSMEN have evaded the ESTATE via Gate 1, ASSIST
IN ANY WAY YOU CAN");// The SMS text you want to send delay(100);

mySerial.println((char)26);// ASCII code of CTRL+Z delay(2000);

mySerial.println("AT+CMGF=1"); //Sets the GSM Module in Text Mode delay(1000);
// Delay of 1000 milli seconds or 1 second

mySerial.println("AT+CMGS=\"+2348108178186\"\\r"); // Replace x with mobile number
delay(1000);

mySerial.println("Restrict Movements, HERDSMEN have evaded the ESTATE via Gate 1, ASSIST
IN ANY WAY YOU CAN");// The SMS text you want to send delay(100);

mySerial.println((char)26);// ASCII code of CTRL+Z delay(1000);

```

```
}
```

```
void SendMessage4()
```

```
{
```

```
    mySerial.println("AT+CMGF=1"); //Sets the GSM Module in Text Mode delay(1000);  
    // Delay of 1000 milli seconds or 1 second
```

```
    mySerial.println("AT+CMGS=\"+2348069467459\"\\r"); // Replace x with mobile number  
    delay(1000);
```

```
    mySerial.println("Restrict Movements, KIDNAPPERS have evaded the ESTATE via Gate 1,  
ASSIST IN ANY WAY YOU CAN");// The SMS text you want to send delay(100);
```

```
    mySerial.println((char)26);// ASCII code of CTRL+Z delay(7000);
```

```
    mySerial.println("AT+CMGF=1"); //Sets the GSM Module in Text Mode delay(1000);  
    // Delay of 1000 milli seconds or 1 second
```

```
    mySerial.println("AT+CMGS=\"+2348033377276\"\\r"); // Replace x with mobile number  
    delay(1000);
```

```
    mySerial.println("Restrict Movements, KIDNAPPERS have evaded the ESTATE via Gate 1,  
ASSIST IN ANY WAY YOU CAN");// The SMS text you want to send delay(100);
```

```
    mySerial.println((char)26);// ASCII code of CTRL+Z delay(2000);
```

```

mySerial.println("AT+CMGF=1"); //Sets the GSM Module in Text Mode delay(1000);
// Delay of 1000 milli seconds or 1 second

mySerial.println("AT+CMGS=\"+2348108178186\"\\r"); // Replace x with mobile number
delay(1000);

mySerial.println("Restrict Movements, KIDNAPPERS have evaded the ESTATE via Gate 1,
ASSIST IN ANY WAY YOU CAN");// The SMS text you want to send delay(100);

mySerial.println((char)26);// ASCII code of CTRL+Z delay(1000);

}

```

```

void SendMessage5()

```

```

{

mySerial.println("AT+CMGF=1"); //Sets the GSM Module in Text Mode delay(1000);
// Delay of 1000 milli seconds or 1 second

mySerial.println("AT+CMGS=\"+2348069467459\"\\r"); // Replace x with mobile number
delay(1000);

mySerial.println("ENVIRONMENT is safe now, you can resume activities");// The SMS text you
want to send delay(100);

mySerial.println((char)26);// ASCII code of CTRL+Z delay(7000);

```

```

    mySerial.println("AT+CMGF=1"); //Sets the GSM Module in Text Mode delay(1000);
// Delay of 1000 milli seconds or 1 second

    mySerial.println("AT+CMGS=\"+2348033377276\"\\r"); // Replace x with mobile number
delay(1000);

    mySerial.println("ENVIRONMENT is safe now, you can resume activities");// The SMS text you
want to send delay(100);

    mySerial.println((char)26);// ASCII code of CTRL+Z delay(2000);

mySerial.println("AT+CMGF=1"); //Sets the GSM Module in Text Mode delay(1000);
// Delay of 1000 milli seconds or 1 second

    mySerial.println("AT+CMGS=\"+2348108178186\"\\r"); // Replace x with mobile number
delay(1000);

    mySerial.println("ENVIRONMENT is safe now, you can resume activities");// The SMS text you
want to send delay(100);

    mySerial.println((char)26);// ASCII code of CTRL+Z delay(1000);
}

void loop() {
button1state=digitalRead(BUTTON1);
delay(5);
button2state=digitalRead(BUTTON2);
delay(5);
button3state=digitalRead(BUTTON3);
delay(5);
button4state=digitalRead(BUTTON4);

```

```
delay(5);
button5state=digitalRead(BUTTON5);
delay(5); if(button1state==1){

    SendMessage1();

}

else if(button2state==1){

    SendMessage2();

}

else if(button3state==1){

    SendMessage3();

} else if(button4state==1){

    SendMessage4();

}

else if(button5state==1){

    SendMessage5();

} else {
delay(1000);

}

if (mySerial.available()>0){
```

```
Serial.write(mySerial.read());
```

```
}
```

```
}
```

## **Appendix B: C ++ (for Water level control)**

```
#define water 2
```

```
#define BUZZER 10
```

```
#define trigPin 12
```

```
#define echoPin 11
```

```
#define SOUND_SPEED 0.034
```

```
#define CM_TO_INCH 0.393701
```

```
#define CM_TO_INCH 0.393701 long
```

```
duration; float distanceCm; float
```

```
distanceInch; void setup (){
```

```
pinMode(BUZZER, OUTPUT); pinMode(water,
```

```
OUTPUT); pinMode(trigPin, OUTPUT);
```

```
pinMode(echoPin, INPUT);
```

```
Serial.begin(9600);
```

```
}
```

```

void waterlevel() { // Clears the
trigPin digitalWrite(trigPin, LOW);
delayMicroseconds(2);

// Sets the trigPin on HIGH state for 10 micro seconds
digitalWrite(trigPin, HIGH); delayMicroseconds(10);
digitalWrite(trigPin, LOW);

// Reads the echoPin, returns the sound wave travel time in microseconds duration
= pulseIn(echoPin, HIGH);

// Calculate the distance

distanceCm = duration * SOUND_SPEED/2;

// Prints the distance in the Serial Monitor

Serial.print("Distance (cm): ");

Serial.println(distanceCm);

Serial.print("Distance (inch): ");
Serial.println(distanceInch); delay(500);

} void loop()

{

digitalWrite(trigPin, LOW); delayMicroseconds(2);

```

```

// Sets the trigPin on HIGH state for 10 micro seconds
digitalWrite(trigPin, HIGH);    delayMicroseconds(10);
digitalWrite(trigPin, LOW);

// Reads the echoPin, returns the sound wave travel time in microseconds  duration
= pulseIn(echoPin, HIGH);

// Calculate the distance

distanceCm = duration * SOUND_SPEED/2;

// Prints the distance in the Serial Monitor

Serial.print("Distance (cm): ");

Serial.println(distanceCm);

Serial.print("Distance  (inch):  ");
Serial.println(distanceInch);
delay(500);  if  (distanceCm>=15){
digitalWrite(water, HIGH);

digitalWrite(BUZZER, LOW);  delay(1000);

}

else      if      (distanceCm<=14){
digitalWrite(water,          LOW);
digitalWrite(BUZZER,          HIGH);
delay(1000);      digitalWrite(BUZZER,
LOW);

```

```
} else{  
  
}  
  
}
```

### **Appendix C: C++ codes (for home automation using IoT)**

```
#include <ESP8266WiFi.h>  
  
#define LED 2 String  
header;  
  
//String header;  
  
String LED_ONE_STATE = "off";  
  
String LED_TWO_STATE = "off"; String  
LED_THREE_STATE = ""; const int  
GPIO_PIN_NUMBER_22 = 4; const int  
GPIO_PIN_NUMBER_23 = 2; const int  
GPIO_PIN_NUMBER_15 = 15;  
  
//LED AT GPIO4  
  
const char*ssid="Airtel 4G MiFi_7526"; const  
char*password="53226947"; unsigned char  
status_led=0;
```

```

WiFiServer server(80);

WiFiClient client; //client =
server.available(); void setup() {
client = server.available();

// put your setup code here, to run once: Serial.begin(115200);

pinMode(GPIO_PIN_NUMBER_22, OUTPUT); pinMode(GPIO_PIN_NUMBER_23,
OUTPUT);          pinMode(GPIO_PIN_NUMBER_15,          OUTPUT);
digitalWrite(GPIO_PIN_NUMBER_22,          LOW);
digitalWrite(GPIO_PIN_NUMBER_23,          LOW);
digitalWrite(GPIO_PIN_NUMBER_15, LOW);

Serial.print("Connecting to ");

//Serial.println(ssid);

//WiFi.begin(password);

WiFi.begin(ssid, password);

//WiFi.begin(WIFI_PASSWORD);          while
(WiFi.status() != WL_CONNECTED) {
delay(1000);

Serial.print("Trying to connect to Wifi Network");

```

```

}

Serial.println("");

Serial.println("Successfully connected to WiFi network");

Serial.println("IP address: ");

//Serial.println(WiFi.localIP());

Serial.println(WiFi.localIP());

server.begin(); } void
loop(){

WiFiClient client = server.available(); if
(client) {

Serial.println("New Client is requesting web page");
String current_data_line = ""; while (client.connected()) {
if (client.available()) { char new_byte = client.read();
Serial.write(new_byte); header += new_byte; if
(new_byte == '\n') {

if (current_data_line.length() == 0)

{

client.println("HTTP/1.1          200          OK");
client.println("Content-type:text/html");
client.println("Connection: close"); client.println();

```

```
if (header.indexOf("LED0=ON") != -1)

{

Serial.println("GPIO23 LED is ON"); LED_ONE_STATE =
"on"; digitalWrite(GPIO_PIN_NUMBER_22, HIGH);

}

if (header.indexOf("LED0=OFF") != -1)

{

Serial.println("GPIO23 LED is OFF");

LED_ONE_STATE = "off"; digitalWrite(GPIO_PIN_NUMBER_22, LOW);

}

if (header.indexOf("LED1=ON") != -1)

{

Serial.println("GPIO23 LED is ON"); LED_TWO_STATE =
"on";

digitalWrite(GPIO_PIN_NUMBER_23, HIGH);

}

if (header.indexOf("LED1=OFF") != -1)
```

```

{

Serial.println("GPIO23 LED is OFF"); LED_TWO_STATE =
"off";

digitalWrite(GPIO_PIN_NUMBER_23, LOW);

}

if (header.indexOf("LED2=ON") != -1)

{

Serial.println("GPIO15 LED is ON");

LED_THREE_STATE = "on";

digitalWrite(GPIO_PIN_NUMBER_15, HIGH);

}

if(header.indexOf("LED2=OFF") != -1) {

Serial.println("GPIO15 LED is OFF"); LED_THREE_STATE =
"off"; digitalWrite(GPIO_PIN_NUMBER_15, LOW);

}

client.println("<!DOCTYPE html><html>");

```

```

client.println("<head><meta name=\"viewport\" content=\"width=device-width, initial-scale=1\">");
client.println("<link rel=\"icon\" href=\"data:,\>");

client.println("<style>html { font-family: Helvetica; display: inline-block; margin: 0px auto; text-align:
center;}");

client.println(".button { background-color: #4CAF50; border: 2px solid #4CAF50;; color: white;
padding: 15px 32px; text-align: center; text-decoration: none; display: inline-block; font-size: 16px;
margin: 4px 2px; cursor: pointer; }");

client.println("text-decoration: none; font-size: 30px; margin: 2px; cursor: pointer;}");

// Web Page Heading client.println("</style></head>");

//Internet of Things Technology for Home Automation and Management

client.println("<body><center><h1>IoT BASED HOME AUTOMATION AND SURVEILLANCE
SYSTEM</h1></center>");

//client.println("<body><center><h3>Internet of Things Technology for Home Automation and
Management</h3></center>");

client.println("<body><center><h3>BY</h3></center>");

client.println("<body><center><h3>NWANKWOEKE, VICTOR OKECHUKWU</h3></center>");
client.println("<body><center><h3>REG. NO: 20174080738</h3></center>");
client.println("<body><center><h3>Electrical/Electronic Dept., </h3></center>");

```

```
client.println("<body><center><h3>SCHOOL OF ELECTRICAL SYSTEMS AND ENGINEERING  
TECHNOLOGY</h3></center>");
```

```
client.println("<body><center><h3>SUPERVISOR:  Engr. Prof. F.K. Opara</h3></center>");  
client.println("<body><center><h3>SUPPORTING      SUPERVISOR:      Engr.Dr.      N.  
Chukwuchekwa</h3></center>");
```

```
client.println("<center><h2>Press on a designated button to turn ON/OFF a device of your choice in  
the house</h2></center>"); client.println("<form><center>");
```

```
client.println("<p>Parlour bulb " + LED_ONE_STATE + "</p>"); // If the  
PIN_NUMBER_22State is off, it displays the ON button client.println("<center>  
<button class=\"button\" name=\"LED0\" value=\"ON\" type=\"submit\">LED0  
ON</button>");
```

```
client.println("<button class=\"button\" name=\"LED0\" value=\"OFF\" type=\"submit\">LED0  
OFF</button><br><br>");
```

```
client.println("<p>Refrigerator " + LED_TWO_STATE + "</p>");
```

```
client.println("<button class=\"button\" name=\"LED1\" value=\"ON\" type=\"submit\">LED1  
ON</button>");
```

```
client.println("<button class=\"button\" name=\"LED1\" value=\"OFF\" type=\"submit\">LED1  
OFF</button> <br><br>");
```

```
client.println("<p>NEXT LOADS HERE... " + LED_THREE_STATE + "</p>");
```

```
client.println ("<button class=\"button\" name=\"LED2\" value=\"ON\" type=\"submit\">LED2  
ON</button>");
```

```

client.println ("<button class=\"button\" name=\"LED2\" value=\"OFF\" type=\"submit\">LED2
OFF</button></center>");

client.println("</center></form></body></html>");
client.println(); break;

} else {

current_data_line = "";

} }

else if (new_byte != '\r')

{

current_data_line += new_byte;

}

}

}

// Clear the header variable header = "";

// Close the connection client.stop();

Serial.println("Client disconnected.");

Serial.println("");

}

```

}