

**INVESTIGATION OF GEO-ENVIRONMENTAL HAZARDS AND
RECLAMATION OF ABANDONED BORROW PITS, SOUTH -
EASTERN, NIGERIA**

BY

**NWACHUKWU, MAUREEN IJEOMA (HND Mining Geology, PGD, Geology)
Reg. No. FUTO/PG/M.Sc./20074771578**

**A THESIS SUBMITTED TO
THE POSTGRADUATE SCHOOL
FEDERAL UNIVERSITY OF TECHNOLOGY, OWERRI**

**IN PARTIAL FULFILLMENT OF THE REQUIREMENTS FOR THE
AWARD OF THE DEGREE OF MASTER OF SCIENCE (M.Sc.) IN
ENVIRONMENTAL GEOLOGY**

FEBRUARY, 2016

CERTIFICATION

I certify that this thesis was carried out by **Nwachukwu Maureen Ijeoma** with registration number (FUTO/PG/M.Sc/20074771578) in partial fulfillment for the award of the degree of M.Sc in Environmental Geology in the Department of Geology of the Federal University of Technology Owerri.

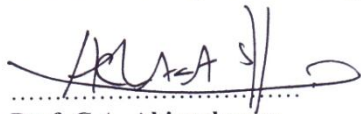

.....
Prof. C.A. Ahirakwem
(Principal Supervisor)

13/08/2016

.....
Date



.....
Prof. G.I. Nwankwor
(Co-Supervisor)

13/06/16

.....
Date



.....
Dr. C.C.Z. Akaolisa
(Head of Department)

16/6/16

.....
Date



.....
Prof. Bede Anusionwu
(Dean, School of Physical Sciences)

17/06/2016

.....
Date

.....
Engr. Prof (Mrs.) K. B. Oyoh
(Dean, Postgraduate School)

.....
Date

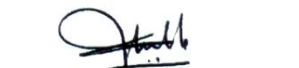

.....
Prof. C.O. Okogbue
(External Examiner)

23-02-16

.....
Date

DEDICATION

This thesis is dedicated to Almighty God who made it possible for me to start and see to the end of this research work in Federal University of Technology Owerri.

ACKNOWLEDGEMENTS

A work of this nature has been made possible through various contributions from people, companies and institution. I therefore see it as a bounding duty to express my hearth felt gratitude to all those who by prayers, advise, moral and financial support helped throughout the program. I wish to express my profound gratitude to Almighty God who gave me the grace and sound mind to start and complete the program.

To my Husband: Dr. M.A. Nwachukwu for his lovely support and encouragement. I also want to thank my amiable supervisor Professor. Cosmas .A. Ahiarakwem for picking interest in my research topic and made me to carry out this research work under his tutelage. Similar thanks is due to Professor G.I Nwankwo for being there for us. Thanks also to the staff of the Institute of Erosion Studies Federal University of Technology Owerri and to Obinna Odiegwu, Chijioke Uzoma, and the staff of GEOPROBE International Consultant Limited for their field assistance.

Special thanks to Dr. Sam Onyekuru who is the Post Graduate School Coordinator in my department. My appreciation goes to the Head of Department Dr. C.C.Z. Akaolisa for his leadership skill. Furthermore, my appreciation goes to other lecturers in the department namely: Dr. O. C. Okeke, Dr. Alex Opara, and Dr. A. Onukwo. Finally, my appreciation goes to my class mates such as Udoka, Ngozi, and Joy etc, for their friendly disposition.

TABLE OF CONTENTS

Title Page	-	-	-	-	-	-	-	-	-	-	i
Certification	-	-	-	-	-	-	-	-	-	-	ii
Dedication	-	-	-	-	-	-	-	-	-	-	iii
Acknowledgement	-	-	-	-	-	-	-	-	-	-	iv
Abstract	-	-	-	-	-	-	-	-	-	-	v
Table of Contents	-	-	-	-	-	-	-	-	-	-	vi
List of Tables	-	-	-	-	-	-	-	-	-	-	viii
List of Figures-	-	-	-	-	-	-	-	-	-	-	ix
List of Plates	-	-	-	-	-	-	-	-	-	-	x
CHAPTER ONE: Introduction											
1.1	General Background	-	-	-	-	-	-	-	-	-	1
1.2	Statement of Problem	-	-	-	-	-	-	-	-	-	4
1.3	Aim	-	-	-	-	-	-	-	-	-	4
1.4	Objectives of the Study-	-	-	-	-	-	-	-	-	-	5
1.5	Justification of the Study	-	-	-	-	-	-	-	-	-	5
1.6	Scope of the Study	-	-	-	-	-	-	-	-	-	7
1.7	Relevance of the Study	-	-	-	-	-	-	-	-	-	7
1.8	Physiography/Climatic Conditions	-	-	-	-	-	-	-	-	-	8
1.9	Geological Setting	-	-	-	-	-	-	-	-	-	8
CHAPTER TWO											
	Literature Review	-	-	-	-	-	-	-	-	-	10
CHAPTER THREE											
	Materials and Methods	-	-	-	-	-	-	-	-	-	17
3.1	Field Investigations	-	-	-	-	-	-	-	-	-	17

3.2	Geotechnical Tests	-	-	-	-	-	-	-	19
3.3	Data Processing	-	-	-	-	-	-	-	20

CHAPTER FOUR

Results	-	-	-	-	-	-	-	-	21
4.1	Environmental Field Measurement and Risk Assessment	-	-	-	-	-	-	-	21
4.2	Discussion of Field Measurement and Assessment	-	-	-	-	-	-	-	23
4.3	Impacts on Engineering Structure/Buildings	-	-	-	-	-	-	-	27
4.4	Factors causing sliding at the pits	-	-	-	-	-	-	-	29
4.5	Measures and Pit Control	-	-	-	-	-	-	-	30
4.6	Geotechnical Laboratory Results	-	-	-	-	-	-	-	32
4.7	Results of Electrical Resistivity Measurement	-	-	-	-	-	-	-	36

CHAPTER FIVE

Summary of Borrow Pit Operation and Reclamation-	-	-	-	-	-	-	-	-	37
5.1	Recommendations	-	-	-	-	-	-	-	37
5.2	Pit Excavation-	-	-	-	-	-	-	-	37
5.3	Reclamation	-	-	-	-	-	-	-	38
5.4	Recommendations	-	-	-	-	-	-	-	40
5.5	Regulatory Measures	-	-	-	-	-	-	-	41
5.6	Conclusion	-	-	-	-	-	-	-	42
Reference	-	-	-	-	-	-	-	-	43
Appendices	-	-	-	-	-	-	-	-	47

LIST OF TABLES

TABLES	PAGES
Table 1: Showing geotechnical test - - - - -	32
Table 2a: Showing resistivity result of Ihiagwa - - -	35
Table 2b: Showing resistivity result of Emekuku - - -	36

LIST OF FIGURES

FIGURES PAGES

Fig. 1:	Project Map of the study area	-	-	-	-	3
Fig. 2:	Geologic map of Imo River Basin	-	-	-	-	9
Fig. 3:	Topographic and drainage map of study area	-	-	-	-	18
Fig. 4a:	Cross-sectional geometry of Emekuku pit	-	-	-	-	24
Fig. 4b	Cross-sectional geometry of Ihiagwa pit	-	-	-	-	24
Fig. 5:	Illustrating measurement procedure or the configuration	-	-	-	-	25
Fig. 6:	Excavation completed borrow pit abandoned	-	-	-	-	29
Fig. 7a:	Perimeter fence decorated with safety warning sign	-	-	-	-	31
Fig. 7b	Danger movement restricted	-	-	-	-	31
Fig. 8:	Showing graph of percentage passing against grain size	-	-	-	-	32
Fig. 9:	Showing graph of density against water content	-	-	-	-	33
Fig. 10:	Showing graph of water content against No. of blows	-	-	-	-	33
Fig. 11:	Showing graph of shear stress against normal stress	-	-	-	-	34
Fig. 12:	Showing 1-D Inversion curves of Ihiagwa and Emekuku	-	-	-	-	34
Fig. 13:	Cross-section of a new borrow pit	-	-	-	-	37
Fig. 14:	Excavation, showing removal of Topsoil to spoil heap	-	-	-	-	38
Fig. 15:	Mining completed, borrow pit abandoned	-	-	-	-	38
Fig. 16:	Arrow shows direction of earth moving using Bulldozer	-	-	-	-	39
Fig. 17:	Testing geotechnical parameters to conform with previous records	-	-	-	-	39
Fig. 18:	Reclaimed borrow pit site turned green for farming	-	-	-	-	40

LIST OF PLATES

PLATES	PAGES
Plate 1: Field measurement of pit depth and slope - - -	22
Plate 2a: Selective mining of sand causing dangerous landscape -	22
Plate 2b: Access roads and drive way to the pit is often death traps -	22
Plate 3a: Abandoned borrow pit showing old slide surface - -	25
Plate 3b: Active borrow pit with rapid sliding - - - -	25
Plate 3c: Heavy duty excavator at work - - - -	25
Plate 4a: Borrow pit turned marshland or swamp - - -	26
Plate 4b: Turned pond, pollute groundwater - - - -	26
Plate 5a: Tension cracks appear as pit wall and slide surfaces get older-	27
Plate 5b: Prevalence of mud crack indicate rapid infiltration - -	27
Plate 6: Family home fence threatened to collapse - - -	28
Plate 7: High tension pole hanging at the crest of the pit - -	28
Plate 8: Reclamation field techniques - - - - -	39

ABSTRACT

Geo-environmental hazards associated with active and abandoned borrow pits are on the increase following rising trend in road construction. This situation presents a major challenge to Citizens, Environmentalists and Governments. Several highway failures have been directly linked to the action of erosion initiated by active or abandoned borrow pits situated close to roads. This study investigated environmental hazards and reclamation requirements associated with abandoned borrow pits in parts of Owerri area, south-eastern, Nigeria. On-sites environmental assessment conducted by direct measurements and supported with photographs showed prevalence of landslides, gully erosion, structural failure, possibility of accidents and threat to ecosystem as well as biodiversity. There is significant threat to groundwater and general environmental safety. A detailed investigation of the Ihiagwa and Emekuku pits revealed poor pit safety factor and high probability of sliding indicative of danger zones, angle of slope 70° - 80° , depth of the pit is 10 m (33 ft) and 21.3 m (70 ft), and pit distance to the road is 15 m and 30 m for Ihiagwa and Emekuku respectively. Geotechnical results show average values of maximum dry density (MDD) and optimum moisture content (OMC) in the two locations is 1.89 mg/m^3 and 14% respectively. The average Plasticity index (I_p) of the soil samples was 19.7% while average of shear strength was 97.65 KN/m^2 . Results of grain size distribution for the two sites show the lateritic soil as sandy with percentage of Clay-silt as 23 and 54 for Emekuku and Ihiagwa respectively. This implies that the lateritic soil is plastic, and can be generally described as cohesive, and suitable as road fill material for which it is being used. Resistivity measurements at the two sites show sandy topsoil 0.43 m and 0.57 m, followed by sandy (lateritic) overburden 3.62 m and 19.17 m representing the borrow material, indicating water table at depth 40.43 m and fluctuates between 47.78 m and 64.81 m for Ihiagwa and Emekuku respectively. It is recommended that borrow pits be professionally sited and fenced, to reduce accidents while in-use. Nigerian mining laws on reclamation of borrow pits must be enforced. Reclamation shall be part of the borrow pit contract agreement. Communities must insist on reclamation of borrow pit after mining with the borrow pit operators. Proper reclamation of borrow pits is by earth-moving, filling the pit with soil and moving land area next to the pit using bulldozer. This is followed by compaction of the earth material, with in-situ and laboratory testing to achieve the original geotechnical ground condition as measured.

An agreement to pit reclamation must be signed by the borrow pit operators with the appropriate government agency before a borrow pit site will be opened. Host community of the borrow pit will be empowered in the agreement to follow up the reclamation exercise soon after the mining operation. Warning signs are to be placed at strategic locations from 500 m to the very location of a borrow pits. This will help to control movement and reduce accidents particularly to farmers and cattle grazers. Reclaimed borrow pit site is turned green for farming or used as recreation parks. It will promote a self-sustaining environment which attracts wildlife; improves ecosystem services and environmental quality.

Key words: *Abandoned mine pits; Geotechnics, Geophysics, Soil excavation, Environmental hazards and Safe, Road construction, Sustainable mining, Environmental quality.*

CHAPTER ONE

INTRODUCTION

1.1 General Background

This study was carried out in selected borrow pits around Owerri, South - Eastern Nigeria, borrow pits investigated were the ARAB Contractors borrow pit at Ihiagwa in Owerri West, along Obinze-Ihiagwa road, and the roadside borrow pit at Emekuku in Owerri North along Owerri-Umuahia highway. Others visited are the active and abandoned roadside borrow pits at Ogbulubi Mbieri close to Okitankwo River, along Owerri-Okigwe highway and the abandoned roadside borrow pit at Iho (Figures 1). These borrow pits were originally established as source of road fill material during construction of the adjacent roads. The ARAB contractors borrow pit is active, and serving the dualization of Owerri-Port-Harcourt highway. The borrow pit at Emekuku are still active, they originally served for the construction of Owerri-Umuahia highway, and are presently the source of earth fill material to nearby roads and other construction sites. The Ogbulubi borrow pit was established during the construction of Owerri-Okigwe highway, became abandoned, but has been presently activated as source of earthfill material to local road projects within Owerri. The borrow pit at Iho originally supplied earthfill material for the construction of Iho-Ogwa road but is presently abandoned, and used for waste dumping. The uncontrolled and uncoordinated excavation of laterite at borrow pits for highway construction and other civil engineering work without the intention of restoring or reclaiming the sites has left much to be desired in terms of the potential hazards associated with abandoned borrow pits. There are hundreds of other abandoned borrow pits scattered in Southeastern Nigeria and all over the country. These borrow pits were originally established as source of earth material for the construction of the associated roads. The borrow pits have lived for decades, following frequent abandonments and later reactivation for the earth material to be used in another location. With increased

population and improvement of road infrastructure in Imo state, abandoned borrow pits are being reactivated and new pits created. There is much excavation and demand for soil material from Ihiagwa and Emekuku borrow pits. However, operators of borrow pits engaged in unsustainable engineering practice in the excavation of soil materials from borrow pit because of the urgency placed on the soil material. The unsustainable engineering practice has led to several potential environmental and geo-environmental hazards which are visible in highway failures, landslides, erosion, surface and ground water contaminant, treat to the ecosystem and biodiversity. It is therefore of great necessity to carry out a study on environmental and geo-environmental assessment of abandoned borrow pit and foster possible restoration and reclamation measures.

In Imo State, several acres of land are degraded by abandoned borrow pits that turn to ponds or waste dumping pits. Infrastructural development which is the priority of Government and the major concern of developing countries like Nigeria has necessitated the increase in highway construction. This has led to a tremendous increase in uncontrolled borrow pits and roadside excavation, and to abandoned pits all around the study area. Not a single pit has ever been reclaimed after use in the region. Some of the borrow pits are wrongly sited due to lack of proper site investigation and use of non professionals.

The use of geophysical method such as Vertical Electrical Sounding (VES) in the investigation of borrow pit site will minimize the trial pit methods that have left behind abandoned pits (Nwachukwu et al., 2012). The presence of such small trial pits has led to several pits littering the study area. Although the area disturbed by a single excavation operation generally might be small, the combined acreage in the area is substantial.

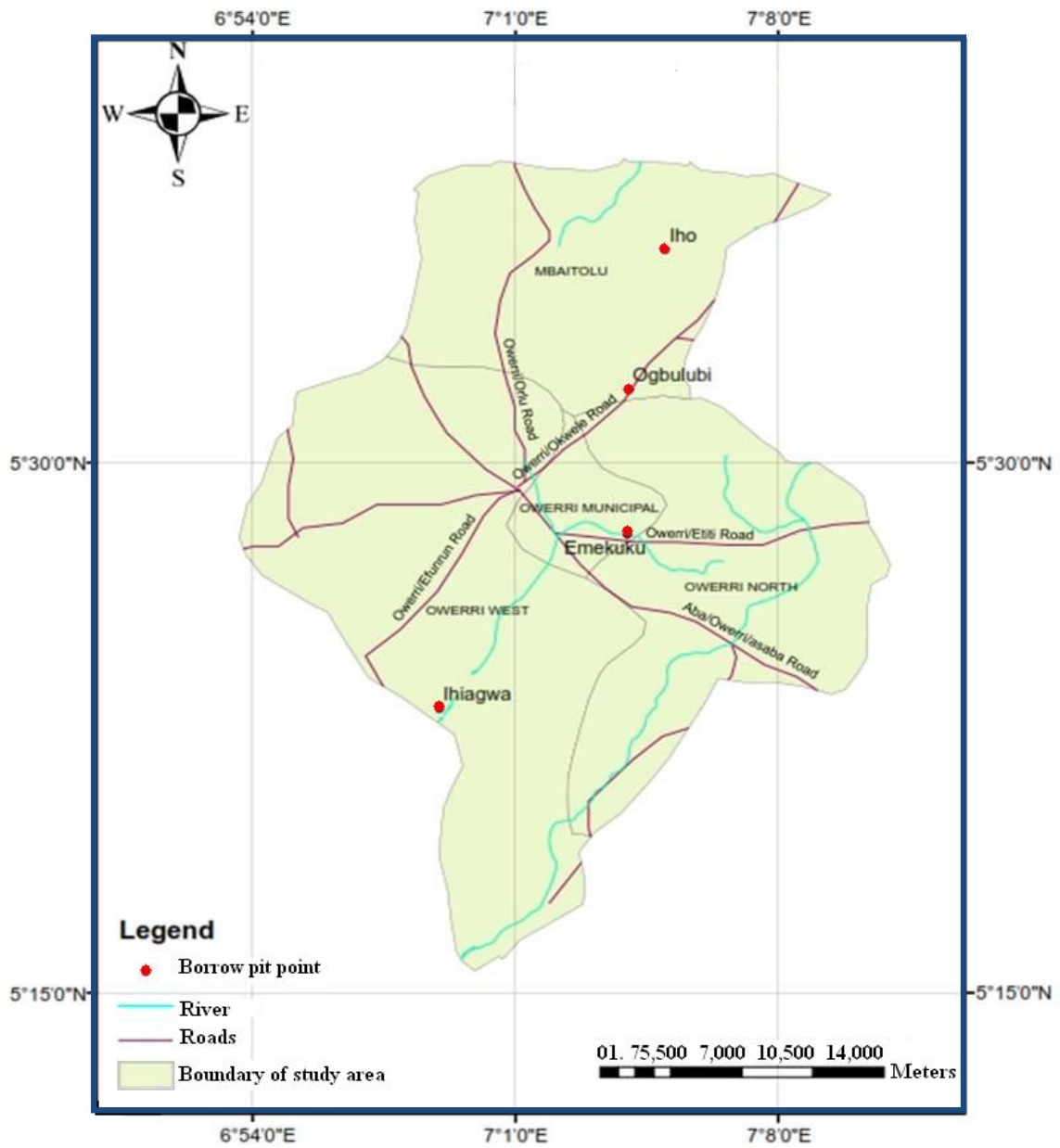

Figure 1: Project map of study area showing location of borrow pits investigated.

1.2 Statement of Problem

The present drive by Imo state government towards road construction and rehabilitation is very much welcome. However, the uncontrolled roadside excavation and reactivation of abandoned borrow pits shares more on environmental degradation and hazards as follows:

- They cause loss of ecosystem services as several benthic organisms and ecological indices are displaced.
- They cause frequent accidents resulting to loss of human life and those of roaming animal
- Frequent landslides associate with active and abandoned borrow pits, often initiating failure of roads and other important structure.
- Abandoned borrow pits waste arable land, resulting to shortage of food production
- When used as waste dumps sites, leachates from the wastes pollute groundwater.
- They initiates gully erosion which in turn destroys the adjoining road and farmlands
- They constitute drainage collection points, form pools and artificial lakes that contaminate groundwater and breed mosquito.
- They become subject of public concern and litigations, thus the need for proper investigation

1.3 Aim

This study is aimed at investigating environmental hazards associated with active and abandoned borrow pits and the possibility of reclamation.

1.4 Objectives of the Study

This study is motivated by the following objectives:

- To improve safety requirement in the operation of borrow pits in the region
- Reclamation enforcement of borrow pits, as not a single pit has ever been reclaimed.
- To increase land for farming and building in Imo state, as the state is poor in land mass.
- To investigate all environmental hazards and safety factors associated with the borrow pits.
- To discourage trial and error methods and encourage scientific selection of sites for borrow pits.
- To improve environmental quality and safety in the region.

1.5 Justification of the Study

According to the Mining Act 1992 - SECT 237 to 239 of the Federal Republic of Nigeria, there are three levels of authorization of land use: (1) casual use, (2) notice level, and (3) plans of operations. Casual use involves minor activity with hand tools, no explosives, and no mechanized earth moving equipment. No permit is required. Notice level activities involve use of explosives and earth moving equipment. The total annual unreclaim surface disturbance must not exceed 5 acres per calendar year. A plan of operations is required for all other surface disturbance activities. A full environmental assessment and reclamation bonding are required. The mining act 1992 section 237, captures the need to protect natural resources: (1) In deciding whether or not to grant an authority or mineral claim, the Minister or mining registrar is to take into account the need to conserve and protect: (a) the flora, fauna, fish, fisheries and scenic attractions, and (b) the features of Aboriginal, architectural,

archaeological, historical or geological interest, in or on the land over which the authority or claim is sought. (2) The Minister or mining registrar may cause such studies (including environmental impact studies) to be carried out as the Minister or mining registrar considers necessary to enable such a decision to be made.

Section 239 captures rehabilitation of excavation or borrow pits or sand dredging sites; stating that before any mining activity commences, operators or contractors will be given permission by the Ministry of Mineral resources, The conditions subject to which an authority or mineral claim is granted or renewed may include such conditions relating to: (a) the rehabilitation, leveling, regressing, reforestation or contouring of such part of the land over which the authority or claim has effect as may have been damaged or adversely affected by prospecting operations or mining operations, and (b) the filling in, sealing or fencing off of excavations, shafts and tunnels, as may be prescribed by the regulations or as the Minister or mining registrar may, in any particular case, determine.

Despite all the mining rules and regulations from parliament, compliance and enforcement of these acts by the relevant government agencies have been ineffective. The lapses in enforcement have created the avenue for contractor and operators to carry out unsustainable practice such that road side excavation. Borrow pits are sited very close to existing roads and roads under construction. Consequent users of the borrow pit abandon it after use without any form of restoration of the land such that contractors later and continuously return to the pits. These processes of abandoning and later reactivating borrow pits become significant in aggravating erosion, landslide, road and structural failures. Often the borrow materials are not very adequate for road fill or road construction. It becomes very necessary that a study of this nature be carried out from time to time to assess and monitor environment. The goal is to educate the contractors, operators and to alert the government and the public on the hazard associated with abandoning borrow pits. That excavation of soil (laterite) for road

construction is mining, and laterite is a mineral resource which must be controlled by government.

1.6 Scope of the Study

This study is limited to investigating the geo-hazards associated with the borrow pit excavation within Owerri, as applicable to other parts of Nigeria. The study investigated selected geotechnical parameters such as grain size distribution, Atterberg limit, direct shear strength and compaction test. These parameters are useful during reclamation operation. Environmental assessment of two abandoned and two active borrow pit sites were conducted. Detailed geotechnical and comparative study of the Emekuku and Ihiagwa sites is presented as case examples and procedure of reclamation and regulatory modifications included with full illustrations and references.

1.7 Relevance of the Study

With the clarion call to reduce environmental hazards, the significance of this study cannot be over emphasized. Little literature exists on environmental geology of roadside excavation and abandoned borrow pits. This study will add to environmental literature on the problems of indiscriminate sitting of borrow pits and the non reclamation after use. It will also provide a framework for government to make laws and strengthen existing laws on borrow pit excavation. Such regulations from government will bring about sustainable engineering practice into the borrow pit excavation establishment and operation. When there is standard operating system as a result of enforcement from government, there will be minimal impact on the environment, restoration and reclamation of abandoned borrow pit or road side excavation. This will enhance environmental awareness, including protection of groundwater quality in affected areas. If well reclaimed, abandoned borrow pit sites can become recreational parks or residential lands.

1.8 *Physiography/Climatic Conditions*

The study area is located within the equatorial rain forest belt of Nigeria. The mean monthly temperature of the area varies from 25 to 28.5°C while the mean annual rainfall is about 2.5 mm. The rainy season (May-October) is characterized by moderate temperature and high relative humidity. The months of November to April have scanty rainfall, higher temperatures and low relative humidity (Uma, 1984). However, the current climate change has resulted in heavy rainfall in the month of November in recent times. The wind direction in Owerri area and environs, of which the study area is a part is mainly South-West, North-West and West. However, the South-West wind direction is the strongest (Anyanwu and Ogbueke, 2003). The area is part of the rain forest belt and the vegetation cover include shrubs and economic trees such as oil palm (arecaceae), Ineedian bamboo (bambusae), avocado pea (Persia Americana), African bread fruit (Trelulia Africana), oil bean (pentaclethra mahophlla), miracle (spondias mombin) and raffia palms (raphia ruffians). Most of the vegetation has been removed through human activities such as farming and construction of civil structures.

1.9 *Geological Setting*

The area is underlain by the Benin Formation (Figure 2), this Formation which is Pliocene to Miocene in age consists of coastal plain sands with minor clay beds. The borrow material being lateritic soil or red earth, constitutes the overburden, followed by the Benin sand.

The Formation contains some isolated gravels, conglomerates, and very coarse sandstone in some places. The mean thickness of the Formation in the study area is about 800 m while the mean depth to water table is about 18.3 m (Avbovbo, 1978). The Benin Formation is overlain by alluvium deposits and underlain by Ogwashi-Asaba Formation which consists of lignite,

sandstones, clays and shale. The Benin Formation provides the aquifer for groundwater storage because of its high porosity and permeability. The incidence of high porosity and permeability as well as shallow water table makes the groundwater in the area very vulnerable to pollution. The geologic setting of the area, therefore, calls for proper land use and waste management practices so as to protect the soil and water resources of the area. The borrow pits investigated are found to be escarpments to the Benin Formation in the Imo River Basin.

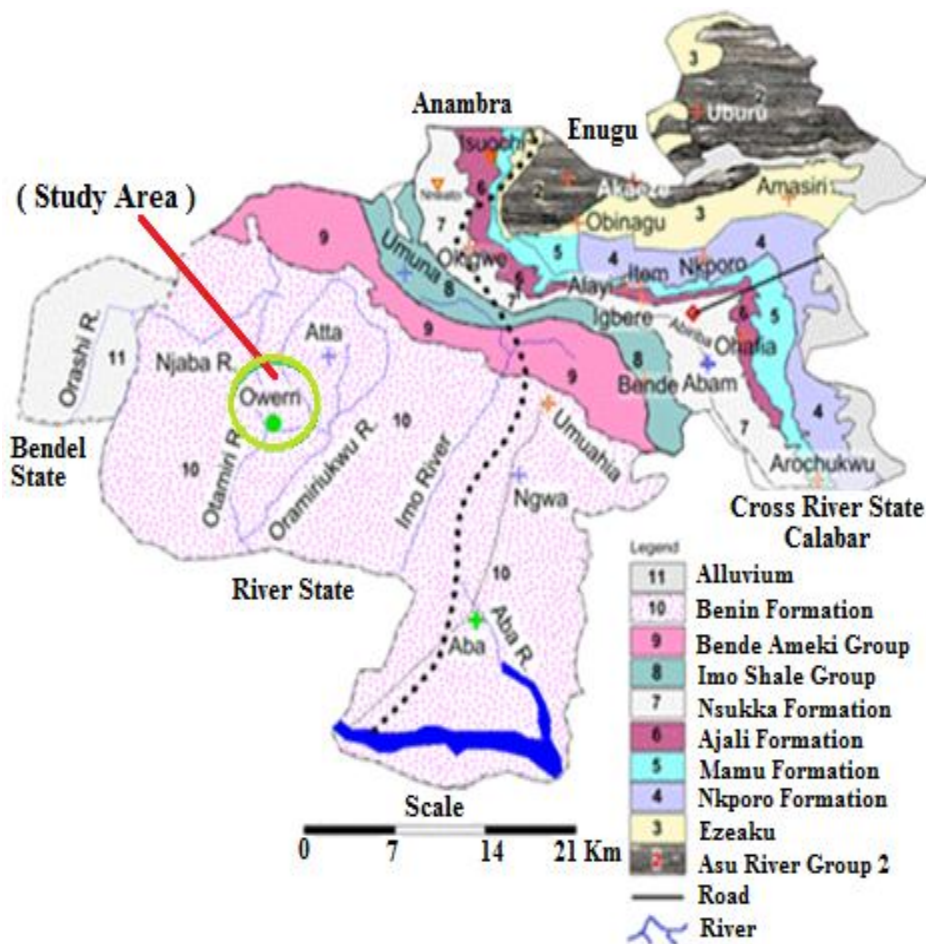

Figure 2: Geologic Map of Imo River basin, showing the Study Area (Source: NGSA, 2004)

CHAPTER TWO

LITERATURE REVIEW

Laterite soil which is the product of borrow pit excavation in the study area is used as a sub base and base course for construction of highways and embankments (Head, 2010). Laterite consists mainly of the minerals, kaolinite, goethite, muscovite and gibbsite which form in the course of weathering. Only those weathering products that are geochemically, mineralogical and most strongly altered are defined as laterite. In countries of the tropics and sub-Sahara, laterite soil is encountered in various engineering projects. In Nigeria uplifted continental land mass made up of basement sediment resulted in the formation of laterite soils which are of relatively good quality for road construction work (Bajomo, 2010). However, most of the laterite soils used in the construction of many Nigeria roads is gotten from pits without geotechnical study to determine their suitability as road fill material. This has consequently led to the loss of productive time on the highway, loss of life and properties, and finally to the repeated contracts of repairing roads instead of channeling such fund to other sectors of the economy.

Some abandoned borrow pits are threats to public safety due to their dangerous vertical walls that are prone to landslides after heavy rains that enhance saturation and liquefaction. In some places, abandoned borrow pits are filled with runoff water from adjoining water bodies and become ponds. More often children use the ponds as swimming pools, and many drown in the process. Borrow pits containing stagnant water also become breeding ground for vectors like mosquito and tsetse fly. Often abandoned borrow pits not containing water serve as dump sites of end of live vehicles. They can also be used for illegal dumping of wastes and hide-out for arm robbers and ritual killers. When these situations arise close to residential areas, major socio environmental problem confront residents.

(Omosanya et al., 2011), recommended that a detailed environmental impact assessment be carried out before a borrow pit license can be obtained from the government. According to them, a task force should be set up by government to indict operators and contractors that do not comply with borrow pit excavation regulations (Berry and Pistocchi, 2003), said that early response to the issue of abandoned borrow pit is to characterize the special features of the effects of unsustainable excavation. They further stated that both active and non-active borrow pits should have proper health, safety and environmental policies properly spelt out. (Ayodele et al., 2009; Nwachukwu et al., 2012). Clearing of vegetation for borrow pit and not restoring it to its original state is a distortion of ecosystem which can lead to the extinction of fauna and flora species. The structure of a soil may be defined as the manner of arrangement and state of aggregation of the soil grains. In a broader sense, consideration of mineralogical composition, orientation and shape of soil grain, nature and properties of soil water may be included in the study of soil structure. A few of such properties are the soil permeability, compressibility and shear strength. The study of soil structure is very important. Laterite is a soil whose internal structure usually presents a globular or concentric circular appearance. This is by oxidized iron concentration (Pisolite) interconnected to assume the appearance of a heavy comb (Venkatra, 2006). The Organization for Economic Co-operation and Development (OECD) defines a “highway” as a line of communication using a stabilized base other than rails or air strip open to public traffic, primarily for the use of vehicles running on their wheels. Historically, many roads or highways were simply recognized routes that had no formal construction or maintenance (Chien and Tang, 2014). Highway or road construction process often begins with the excavation of red earth and rock used as road-fill material often beside the road under construction. It includes construction of embankment, bridges and tunnels and removal of vegetation followed by the laying of pavement material. A variety of road building equipment like bulldozer, grader and trucks are employed in road

construction (Mawdesley et al., 2004). After design, approval, planning, legal and environmental consideration have been addressed, alignment of the road is set out by surveyors. According to (Shah and Dawood, 2011), the gradient and radii are designed and staked out to best suit the natural ground levels and minimize the amount of cut and fill. Care is taken to preserve reference benchmarks, using erosion sediment controls to prevent detrimental effects.

Old roads surfaces, fence and buildings may need to be removed before construction can begin, some trees in the road construction area may be marked for retention. These protected trees should not have the topsoil within the area of the trees drip line removed and the sides should be kept clear of construction material and equipment. Much of the vegetation may be mulched and kept aside for use during reinstatement. The topsoil is usually stripped and stockpiled nearby for rehabilitation of newly constructed embankment along the road. Stumps and roots are removed and holes filled as required before earthwork begins. The process of earthwork includes excavation, removal of material to spoil, filling, compacting, construction and trimming of rock or other unsuitable materials. Moisture content is managed and replaced with standard fill compacted to 90% compaction (Allen et al., 2001). Generally, fill materials should be free of organics, meet minimum California Bearing Ratio (CBR) and have acceptable plasticity index. The lower fill comprises sand or sand rich mixture with gravel which acts as an inhibitor to the growth of plants or other vegetable matter (Budhu, 2011).

Careful excavation and design of borrow pit slope can reduce landslide accidents prevalent in an area. Deep borrow pits often with negative slope support frequent landslides in an area. Landslide is a geological phenomenon which occurs as a result of ground-water movement and is common in large abandoned and active borrow pits. It can occur as rock fall, failure of unstable slopes, and debris flows on slope (Hewitt, 1992). Many different triggers cause landslides. They include intense or prolonged rainfall, earthquakes, poor design of mine pits,

and snow melting. On earth, the volume of mass movements spans fifteen orders of magnitude, and landslide velocity extends over fourteen orders of magnitude, from millimeters per year to hundreds of kilometers per hour. Despite information contained in landslide inventory maps, very few attempts have been made to assess their reliability, landslide identification needs to be carried out by experienced geomorphologists.

(Varnes, 1998) and the IAEG Commission on Landslides and other Mass-Movements proposed that the definition adopted by (UNDRO, 1982) for all natural hazards be applied to landslide hazards. Landslide hazard therefore has the probability of occurrence within a specified period of time and within a given area potentially subjected to sliding. Due to the variety of landslide types and the possibility that the landslide will evolve abruptly from one type of movement to another (e.g., when a soil slip is transformed into a debris flow), the total mass movement is also difficult to predict due to variable factors. Many methods have been proposed to evaluate landslide hazard spatially and according to (Guzzetti et al., 1999), the two most promising methods are: (a) Analysis based on the statistical analysis of geo-environmental factors related to the occurrence of landslides, and (b) A deterministic modeling method based on simple mechanical laws that control slope instability. Multivariate statistical models provide the best results for large areas and where the relationships between determining factors and landslide occurrence are complex. These models provide quantitative information on the spatial pattern of landslides. Good multivariate models usually perform better than the original inventory map in predicting the occurrence of landslides (Ardizzone et al., 2002) but do not explicitly incorporate the temporal aspect of movement. Physically based models perform well for landslides whose behavior is easily predicted by simple mechanical laws (e.g., soil slips and rock falls), but they too lack consideration of the temporal aspect of landslides. Attempts to introduce the time component into hazard models

have been proposed by (Agostoni et al., 2000), who incorporated historical landslide events in a multivariate discriminate model.

Moreover (Coburn et al., 2000) proposed a probabilistic model of landslide occurrence based on a catalogue of historical landslides (Guzzetti et al., 2002), who used a physical model to study rock fall hazard, simulated the time effect by launching a large number of boulders from each rock fall source area. The experience gained in numerous hazard investigations has shown that, although quantitative, indirect methods of assessing landslide hazards are preferable. No single method has proved to be superior in every area and for all types of landslide. Selection of the statistical technique and the type of deterministic model appears less important than the availability, quality, resolution and abundance of input data, including those derived from inventory maps. Equally important is the ability of the geomorphologists to interpret the model results and to design appropriate forms of protection for the different hazard zones.

According to (Pimentel et al., 2009), soil erosion is second only to population growth and it is the biggest environmental problem the world is facing. Erosion is termed accelerated when the rate of soil removal exceeds that of soil formation. The rate of soil formation at any point in time is governed by the factors of parent rock material, topography, climate and vegetation (Sabatini, 2002). For the most part, erosion which is the process of weathering and transport of sediment, soil, rock and other particles in the natural environment is caused by two main catalysts, wind and water. These materials cause degradation in many forms and affect a full spectrum of natural environment in the presence of excavation and abandoned borrow pits.

(Akpokodje et al., 2010 ; Hudec et al., 2006) observed that the cleaner, more porous and weakly cemented sands of an abandoned pit are the most prone to initiate erosion and landslide (Ezezika and Adetona, 2011) concluded that community based low-technology land management practices, and public awareness programs through workshops could halt the

development of many gullies from abandoned borrow pits. Human activities that trigger erosion such as roadside excavation, abandoned borrow pits, and roadside waste disposal must not be allowed. In this case, there is need to intensify effort towards sustainability studies on these vices that may trigger gully erosion, and report findings to the public through sustainability seminars (Obiefuna and Adamu, 2011) recognized geological and geotechnical parameters as main causative agents in the formation of gullies. The varying opinions of these researchers become significant from one location to another. For example, environmental problems of abandoned borrow pits in the tropical rain forest belt of study area are due to high rainfall intensity. (Troeh et al., 1980; Fiener et al., 2013) have described amount of precipitation, energy and intensity of rainfall as the major physical factors contributing to the hazards associated with abandoned borrow pits.

The soil characteristics and the geological set up of the study area, Ihiagwa and Emekuku have enhanced the occurrence of erosion activity (Ebola and Nwachukwu, 1985) hydrogeological and geotechnical parameters as causative agent in the generation of erosion in the rain forest belt of Nigeria (Nwajide and Hogue, 1979) identified topography, climate and soil characteristics as major causes of erosion. There could also be man-made factors such as poor land use practice, poor road design and construction, and unsustainable engineering excavation of borrow pit.

According to (Nwachukwu and Feng, 2012), improvement of urban and rural infrastructure such as road construction in particular, has led to increased pollution stress on groundwater quality in many developing countries. For example, borrow pits from where materials were collected for road projects are usually abandoned instead of reclaimed. Soon after, these abandoned borrow pits become urban waste disposal pits. Aquifer pollution stress arises as the pits become point sources of groundwater pollution in the area or regions where water table is near surface as applicable in the study area. Again, lack of storm water management

during road construction and other open engineering sites such as road side excavation causes erosion of topsoil which eventually creates gully erosion.

The clearing of vegetation, stripping of topsoil and removal of gravel from borrow pits could cause erosion downhill and reduce soil fertility. The operation of heavy equipment along access roads and surrounding areas of the borrow pits will lead to compaction, thus disturbing the virginity or natural state of local soils (Bello, 2011). There is also the possibility of spillage or leakage of petroleum products from the construction equipment into the ground.

CHAPTER THREE

MATERIALS AND METHODS

3.1 Field Investigations

Four sites were identified for field assessment and were as follows: Ihiagwa, Emekuku, Ogbulubi and Iho. Ihiagwa and Emekuku were deeply investigated. Environmental assessment of the sites was accomplished by direct measurements and photographs. Geophysical technique by electrical resistivity method was used to investigate depth of the lateritic topsoil in each of the sites. The elevations and coordinates of the pits were measured with E-Trex Geographic Positioning System (GPS) and recorded in a spread sheet. Measured coordinates were digitized to produce a GIS contour map of the study area (figure 3). Pit geometry, including angle of slope and recent sliding surface, overburden, and the depth were physically measured in the field and recorded. Potential hazards and environmental impacts of both the abandoned and the active pits were assessed. Ihiagwa pit was established by ARAB contractors for the dualization of Owerri to Port Harcourt highway. Emekuku pit earlier established for the construction of Owerri to Umuahia road was now generally used by the public as source of red earth for several road and landfill projects. Lateritic soil, described as red earth overburden material is specifically used as road fill material. Hand auger was used for the collection of composite samples from Emekuku and Ihiagwa pits and tested, to ascertain the geotechnical properties of the lateritic soil. Their economic importance was investigated and compared with the prevailing environmental degradation to obtain a cost benefit analysis.

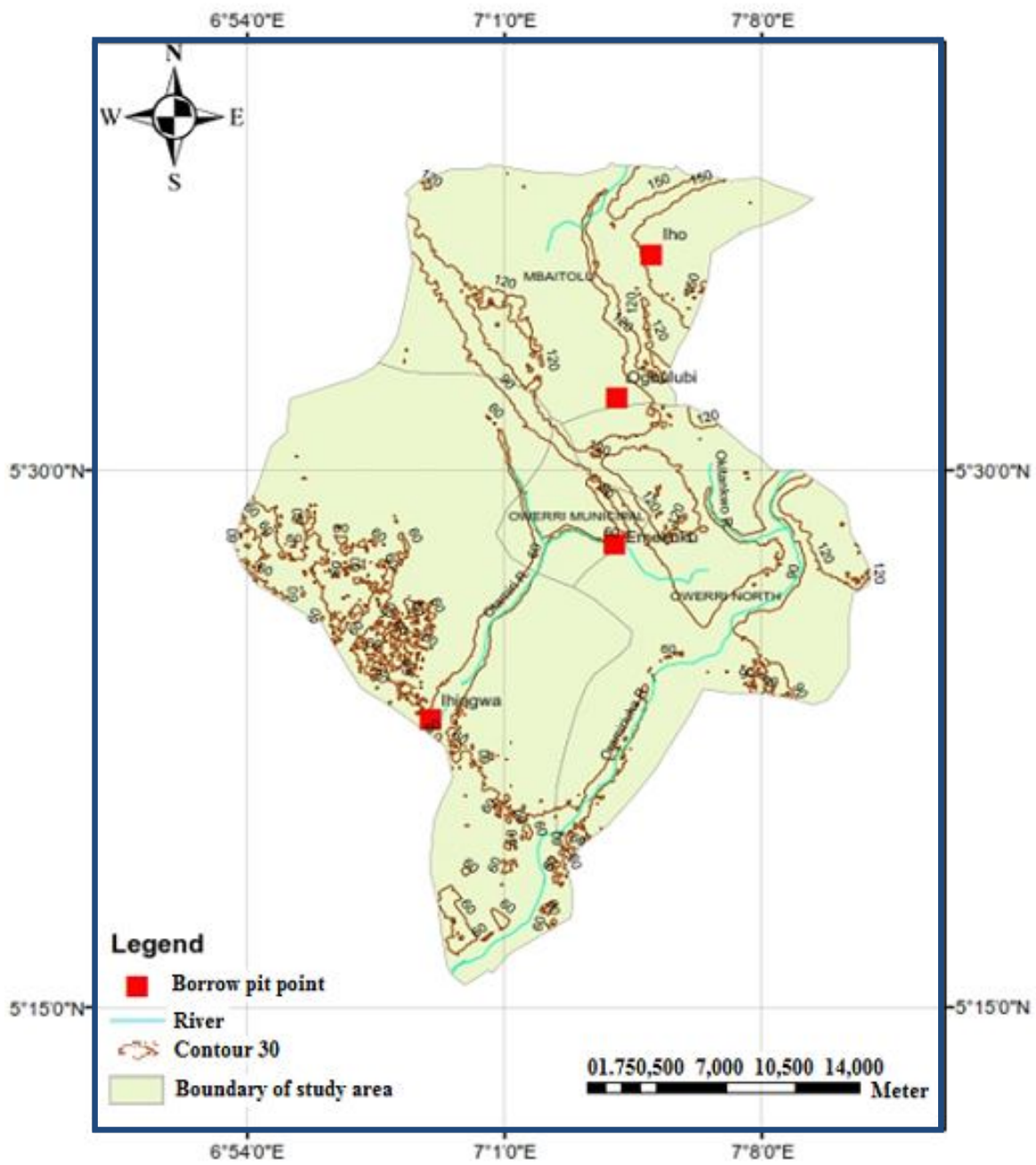

Figure 3: Topographic and drainage map of study area

3.2 Geotechnical Tests

In each pit, three replicate samples were collected and properly homogenized to make one composite sample. The two composite samples, one from Ihiagwa and the other from Emekuku were subjected to the following tests:

- Compaction test to determine Maximum Dry Density (MDD) and Optimum Moisture Content (OMC).
- Plastic and liquid limit test to determine Plasticity Index (I_p).
- Shear strength test to determine normal stress (σ_n) and shear stress (τ) both in KN/m^2
- Grain size distribution to determine particle size by wet sieving using a set of sieves.

The abovementioned tests were carried out at Institute of Erosion Studies (IES) FUTO.

Calculation procedures for mass retained, % retained and % passing

Example:

To calculate the % passing for sieve 1.0

We can proceed as follows

Total mass = 64.6g

Mass retained on sieve 1 = 1.6g

Quantity passing = Total mass – mass retained

$$64.6g - 1.6g = 63g$$

The percentage retained was gotten as follows

$$\% \text{ Retained} = \frac{\text{Mass Retained} \times 100}{\text{Total Mass}}$$

$$\% \text{ Retained} = \frac{1.6 \times 100}{64.6} = 2.48\%$$

$$\% \text{ Passing} = 100 - 2.48\% = 97.5\%$$

3.3 Data Processing

Field coordinate data were converted from degrees, minutes and seconds to digital coordinate values and then transformed to Geographic Information System (GIS) map using ArcGIS 10.1. Elevation data obtained were also applied to the ArcGIS software to obtain a topographic and drainage map of the study area. Electrical resistivity data were subjected to Advanced Geosciences Incorporation (AGI) 1D inversion technique analytical software was used for processing, geotechnical data, and Microsoft Excel 2007 software was used to plot the graphs. The environmental field assessment and the analytical results became integrated, such that a comparative analysis of the Ihiagwa and the Emekuku borrow pit sites was carried out. Integrating the Ihiagwa and Emekuku site conditions with the field assessment of Obulubi and Iho sites, brought about a detailed geo-environmental assessment of borrow pit activities in the project area.

CHAPTER FOUR

RESULTS

4.1 Environmental Field Measurements and Risk Assessment

Borrow pits located near settlements are a source of concern in terms of human health and safety. Such borrow pits could become breeding areas for mosquitoes during the rainy season should they become inundated with water. Other health and safety concerns could be to children who may use the collected water as play grounds and contact water borne diseases such as bilharzias or possibly drown. All the borrow pits were found too close to the roads such that they are a danger and could cause accidents to the motoring public. The pits slope were near vertical and unstable, making way for regular sliding and slumping of the walls and trees into the pit. In the four abandoned pits investigated, they presented a situation of unsustainable engineering practice and environmentally unsafe area for human activity. The areas under study are classified as degraded land and danger zones where no meaningful agricultural activities can be carried out. The animal and plant species within this area are threatened and are likely to face extinction due to the destruction of their habitat. The areas are characterized by thick and dense vegetation typical of the tropical rainforest.

The soil is mostly sandy and gravel-like. The presence of trees, shrubs and grasses is responsible for the dense vegetation within the areas. The topsoil, less than 1 m thick, consists of dark humus soil for agriculture. This top soil is followed by the reddish lateritic soil which constitutes the borrow material. Thickness of overburden or the borrow material as measured in Emekuku pit is 8 m (Plate 1). The selective mining of sand causes dangerous landscape in Ihiagwa pit (Plate 2a,b), further excavation of the water saturated sand and gravel beds for building and other engineering projects other than roads, form dangerous landscape; triggers erosion, form cavities or cause landslides.

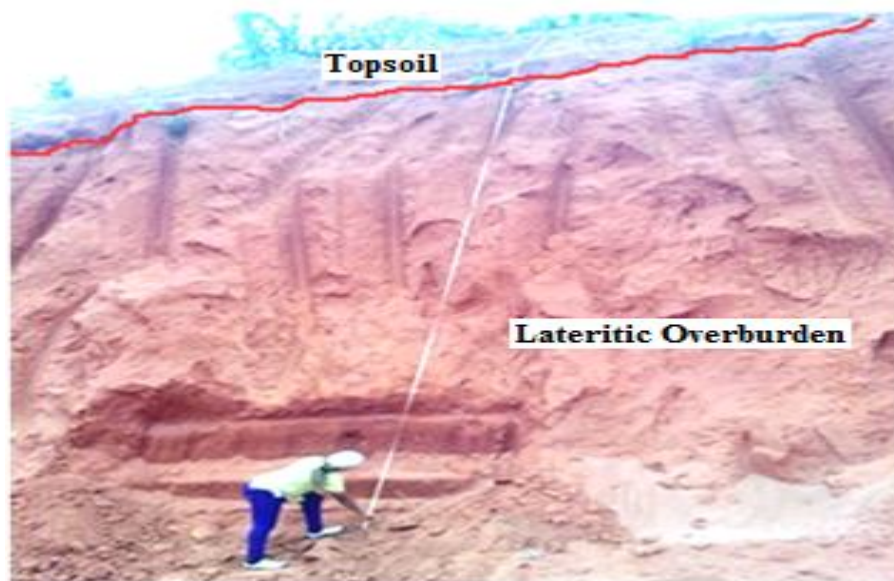

Plate 1: Emekuku field measurement of overburden thickness

Ihiagwa



Plate 2a: Selective mining of sand causing dangerous landscape
b: Access roads and drive way to the pits is often death traps caused by erosion

4.2 Discussion of Field Measurement and Assessment

In the two sites visited there are issues of landslide which is a serious environmental problem in the area. Landslide is a down slope movement of rock and soil along slip surfaces is also associated with disturbance of the equilibrium which normally exists between stress and strain in material resting on slope. This relationship is dependent on factors like height, steepness of the slope, density and strength (cohesion and friction) of the material on the slope. The geometry of the two sites, Ihiagwa and Emekuku revealed a slope angle of between 70° to 80° (Figure 4a,b). The slopes were compromised during the excavation process. Also the pit slope has been weakened due to heavy rainfall common to the area from March to September. From the vertical electrical sounding carried out, the study area is a sandy geological formation resulting to higher permeability which will also account for groundwater movement and pore water pressure around the sloppy region giving rise to resultant mass movement of the soil on the sloppy surface. The resultant effect of landslide in the area has led to loss of lives and damage to properties. Community personnel interviewed affirmed that since the abandoned borrow pits where the community has suffered unquantified loss of properties. Porosity of the sandy soil and its moisture content as well as slope angle, have aided the occurrence of landslides in the area. The illustration of measurement procedure of the two sites (Figure 5).

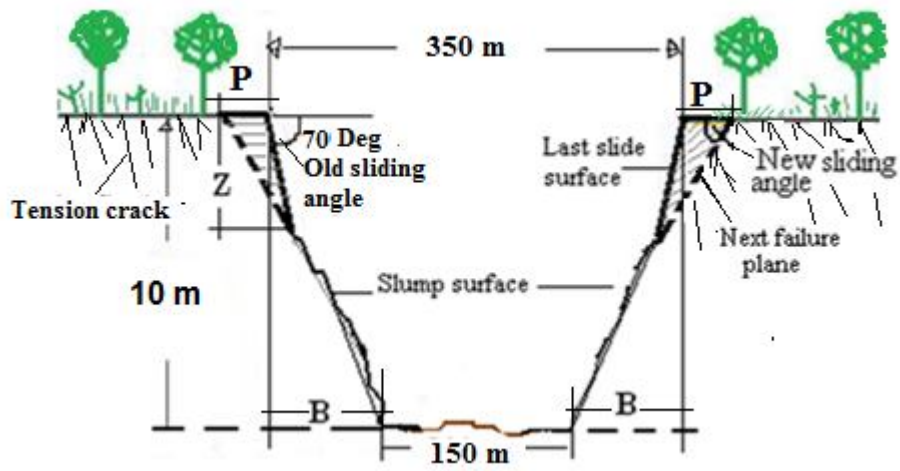

Figure 4a: Cross-sectional geometry of Emekuku pit

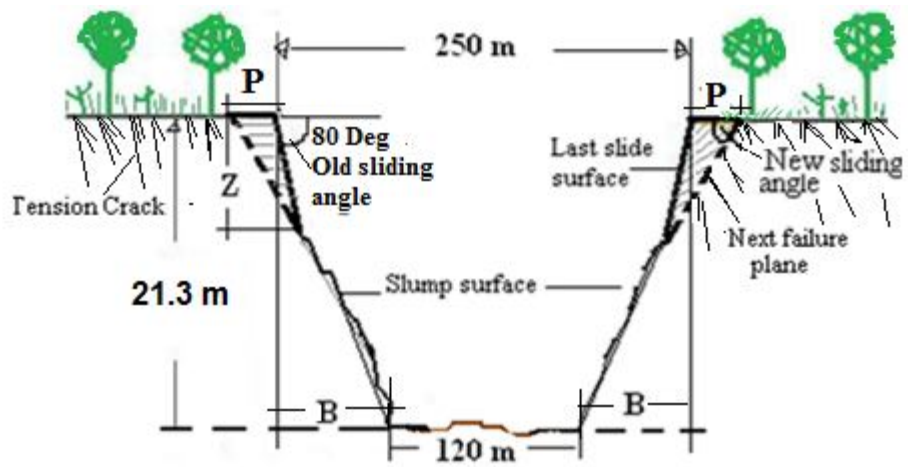

Figure 4b: Cross-sectional geometry of Ihiagwa pit

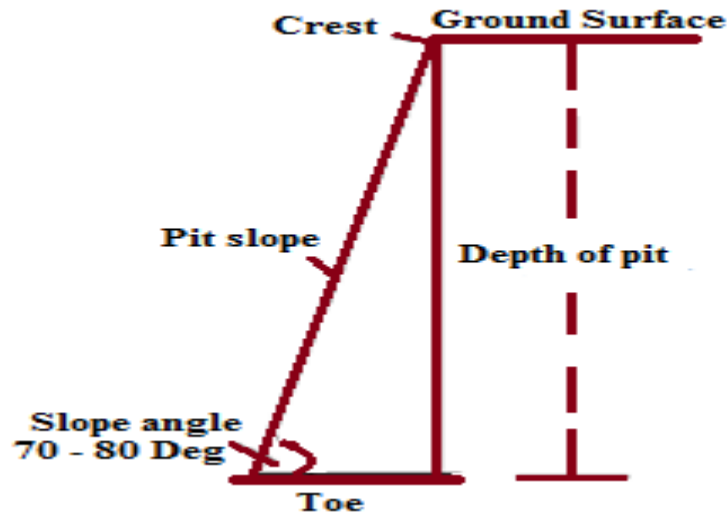

Figure 5: Illustrating measurement procedure of Emekuku and Ihiagwa pit

With active fresh slumping surface of the lateritic soil constituting the overburden, sliding of the lateritic face goes on with falling of trees due to deep excavation that leaves very unstable pit slope angle. Often this results in accidents, loss of live and destruction of excavators (Plates 3a, 3b and 3c).

A: Ihiagwa site



B: Emekuku site



C: Crawler mounted excavator at Emekuku



Plate 3a: Abandoned borrow pit showing old slide surface and recent slumping
 b: Active borrow pit with rapid sliding and palm trees hanging next to pit crest often sliding and causing damages to the excavator
 c: Heavy duty excavator at work

Soon after, abandoned borrow pits in the area could turn to marsh land or ponds (Plate 4a, b). This situation reduces environmental quality by breeding of mosquitoes, polluting the groundwater, often there is loss of life as children swim in the pond or fetch water from the pond. Prevalence of tension cracks on abandoned pits (Plate 5a, b) and mud cracks on dried marsh land in the area also facilitate infiltration and transport of pollutants to groundwater. Structural failure is initiated when the material is stressed to its strength limit, thus causing fracture or excessive deformation. Overburden stress, increasing rainfall intensity and saturation and fracture due to excavation initiate plane of failure. This situation reduces cohesion, initiates plane of failure which constitutes a sliding surface as soon as the shear strength is overcome.



Plate 4a: Borrow pit turned marsh land or swamp 4b: Turned pond,

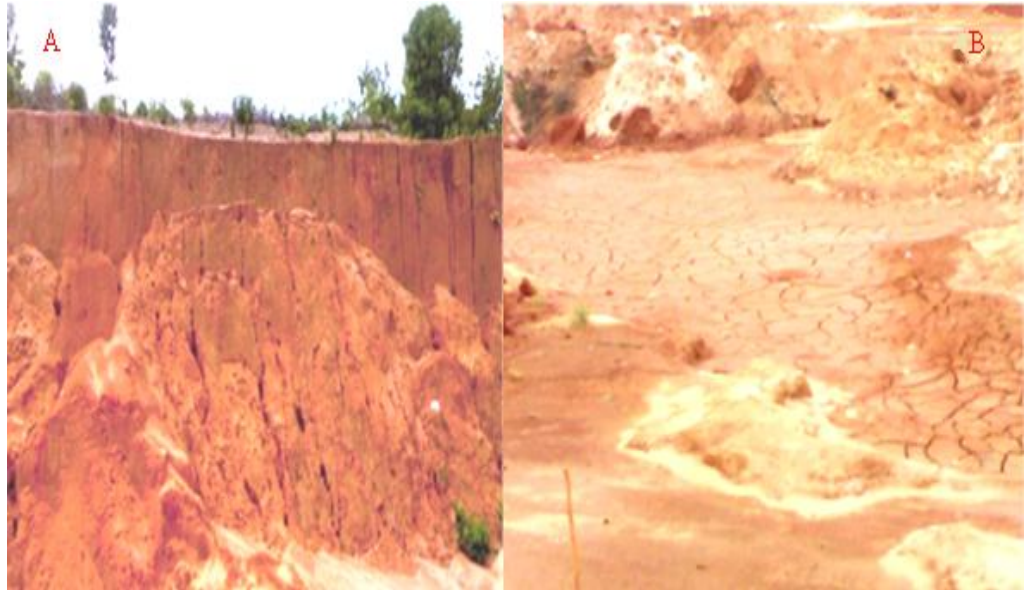

Plate 5a: Tension cracks appear as pit wall and slide surfaces get older, thus reducing slope stability of the pit.

b: Prevalence of mud crack indicate rapid infiltration band possibility of groundwater contamination in the area.

4.3 Impacts on Engineering Structure / Buildings

At Ogbulubi borrow pit site, about 20 m from the edge of the abandoned borrow pit, is a fence and story building under threat of sliding (Plate 6). Because of the fact that heavy duty equipment like bulldozers, pay loader and trucks were used for excavation and loading of the laterite soil to designated construction sites, the equipment have the tendency of causing vibration that sends lateral waves to the surrounding structures which also weaken the foundation of the structures and cause displacement. Should there be any slight rain, the pore spaces created will be avenue to transfer water and finally produce cracks that will make the structure collapse. The owner of the story building is already in court with the pit operators, yet excavations were still in progress. Incidents of slide affecting a fence and or building will certainly cause a huge economic loss.



Plate 6: Family home; a duplex, fence threatened to collapse by next sliding as excavation still goes on

On top of one of the abandoned borrow pits at Owerri-Okigwe highway is a high tension electric pole (Plate 7).



Plate 7: High tension pole hanging at the crest of an abandoned borrow pit, may collapse by the next sliding

From the edge of the slope to the high tension pole is about a distance of 20 m. There is a thick vegetation cover of India bamboo which has stabilized the soil from sliding. But that does not guarantee the safety of the pole from sliding after any heavy rain. The high tension pole poses a lot of environmental hazard to the residents and travelers plying that route. If there is any heavy down pour of rain, there will be ground water movement that will weaken the soil material. There are great environmental and social implications if the pole should collapse. Firstly it will lead to paralysis of commercial and industrial activities for communities that are linked to the high tension pole. It can also lead to death if the pole falls on buildings and human beings.

4.4 Factors causing sliding at the Pits

The classical approach used in designing open pit excavation is not applied in the study area. There is no pit design, and that implies no proper consideration to safety and possibility of sliding in the pits investigated. Critically, there is no consideration to the relationship between forces resisting sliding (B_f) associated with the sliding base distance (B) and the probability of Sliding (Figure 6) show force resisting sliding (C) possessed by the base rock and the overburden pressure (D) initiating sliding.

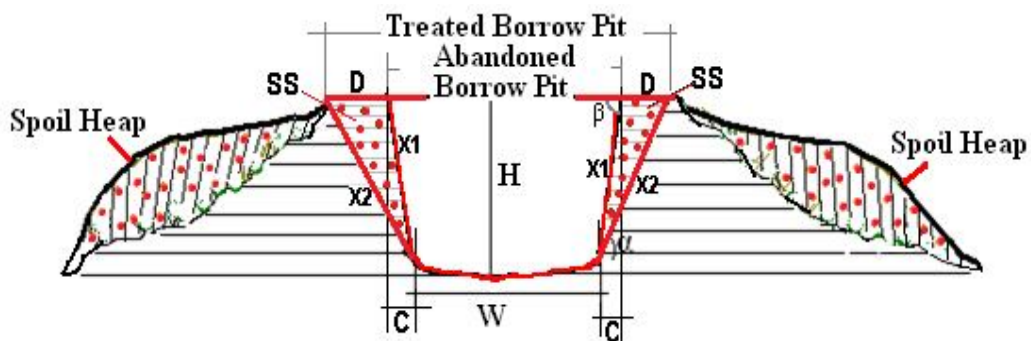

Figure 6: Excavation completed, Borrow pit abandoned

The Factor of Safety (F) of the pits is defined as

$F = C/D$, and sliding is assumed to occur when F is less than unity. For assurance of safety, C must be greater or at least equal to D. F is controlled by the following factors:

- Type of rock material constituting the overburden (Unit weight of rock)
- Presence of trees increasing overburden pressure or tension
- Presence of external force such as buildings, machineries, vibration or seismic waves increasing tension
- Degree of water saturation (Unit weight of water)

If α = Sliding angle increases, **D** reduces, thereby increasing safety factor, and reducing the probability of sliding. Other conditions are as follows:

SS = Sliding surface; established by tension crack is enhanced by water saturation, thereby increasing probability of sliding. This surface should be removed as a treatment to the pit wall to increase slope stability at the landfill.

α = Pit slope angle when reduced, enhances slope stability

H = Effective depth of pit affects pit slope angle and stability of slope

H = Effective Depth, W = Width, α = Angle of slope after treatment (60-75 degrees),

β = Angle of slope before treatment 75-90 degrees), X1 = Pit wall before treatment,

X2 = Pit wall after treatment, C = Force resisting sliding, D = Overburden pressure

SS = Possible sliding surface or the excavated treated surface

4.5 Safety Measures and Pit Control

Borrow pits active or abandoned should be provided some safety measures to reduce accidents and risks. There should be perimeter fencing of the pit area (Figure 7a), to wade off sliding of human beings and other roaming animals into the pits. There should be only one

gate for both entry and exit into the pit. The pit area and the gate must be guarded 24 hours daily by vigilante and security personnel to avert trespassing.



Figure 7a: Perimeter fence decorated with safety warning sign

Warning signs (Figure 7b) are necessary at strategic locations to inform passersby of the imminent danger ahead. Such signs must be simplified and easily understandable by all, including cattle rearing persons traversing the area.



Figure 7b: (i) Danger; Movement Restricted, abandoned borrow pit 100 m ahead
(ii) Danger; Grazing Restricted, abandoned borrow pits 200 m ahead

4.6 Geotechnical Laboratory Results

Grain size analysis of the borrow material suggests that the particle size ranges from very fine to very coarse, with significant clay silt content (Figure 8 and Table 1). This implies that the lateritic soil is plastic, and can be generally described as cohesive, and suitable as road fill material for which it is being used.

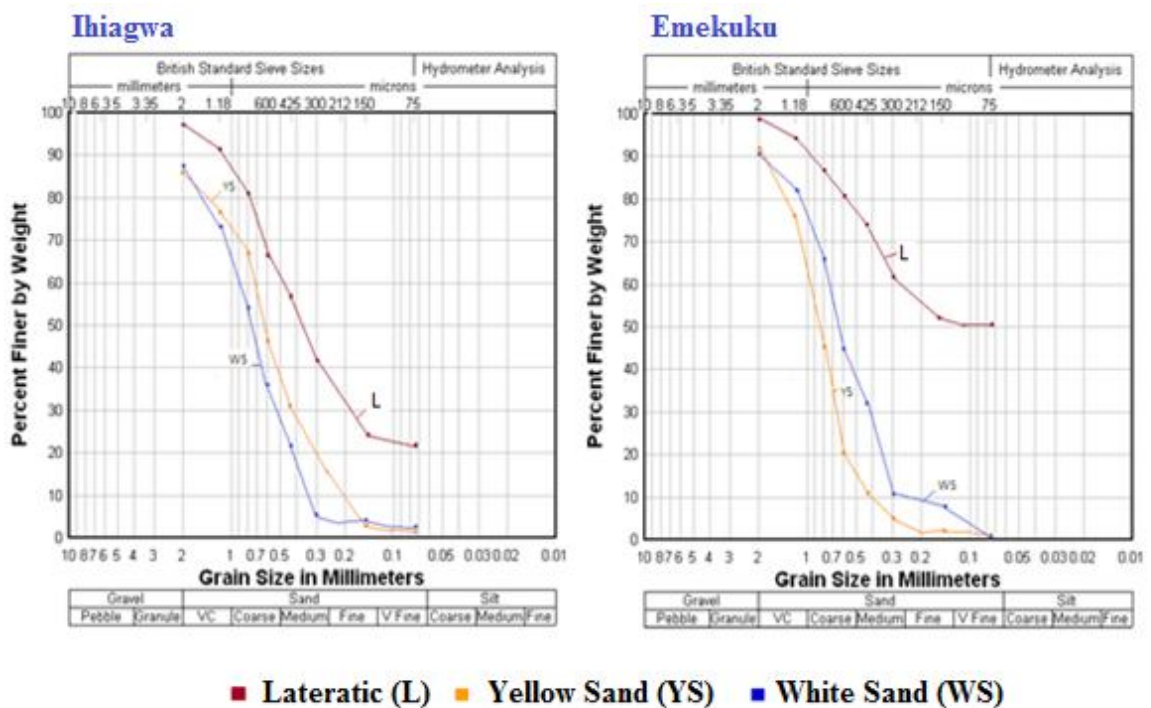

Figure 8: Showing Graph of Percentage Passing (%) against Grain Size (mm) at Ihiagwa and Emekuku

Table 1: Showing Geotechnical test

Grain size distribution	Emekuku	Ihiagwa
Fine sand	0.3 %	0.5 %
Medium sand	20 %	30 %
Coarse sand	0.62 %	0.68 %
Clay silt	23 %	54 %

A maximum dry density (MDD) range of 1.84 to 1.93 mg/m³ was measured at the two sites, with optimum moisture content (OMC) of 13.9% for Ihiagwa and 14.3% for Emekuku.

(Figure 9) the two samples tested, plasticity index (I_p) of 18.2% and 21.2% were obtained for the Ihiagwa and Emekuku sample respectively (Figure 10).

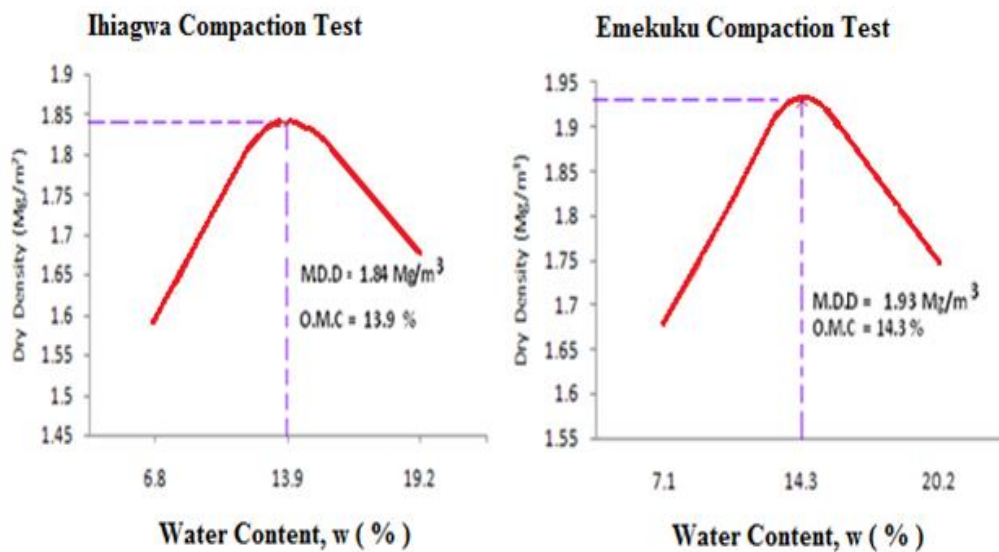

Figure 9: Showing Graph of Density (mg/m³) against Water Content, w (%)

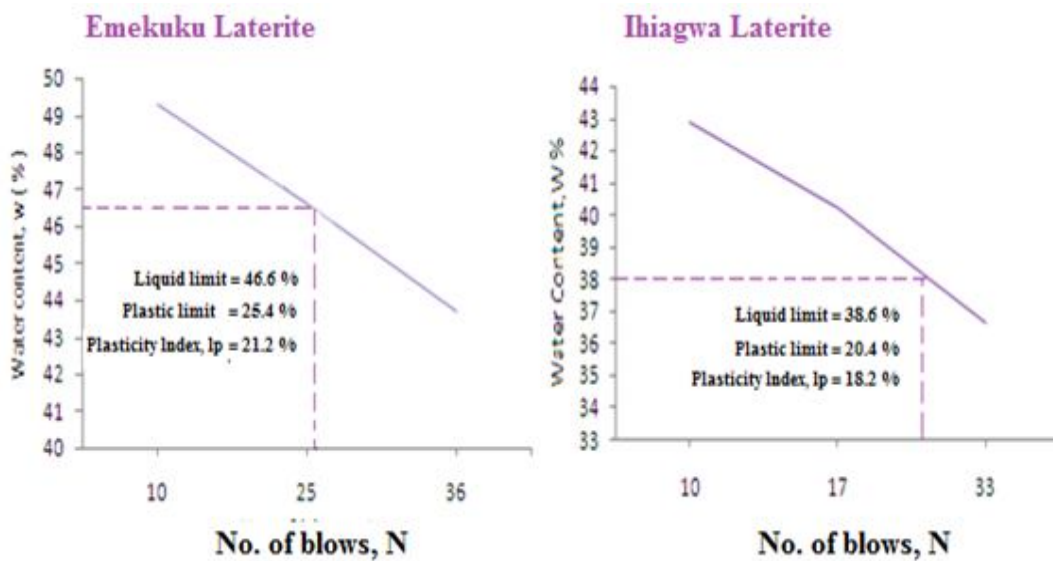

Figure 10: Showing Graph of Water Content, w (%) against No. of Blows, N

Shear strength of 99.6 KN/m² was obtained for Ihiagwa sample and 95.7 KN/m² for Emekuku sample with angles of internal friction of 27 and 26 degrees respectively (Figure 11). These values are significant to be considered when using the soil for road fill material for durability and good road quality.

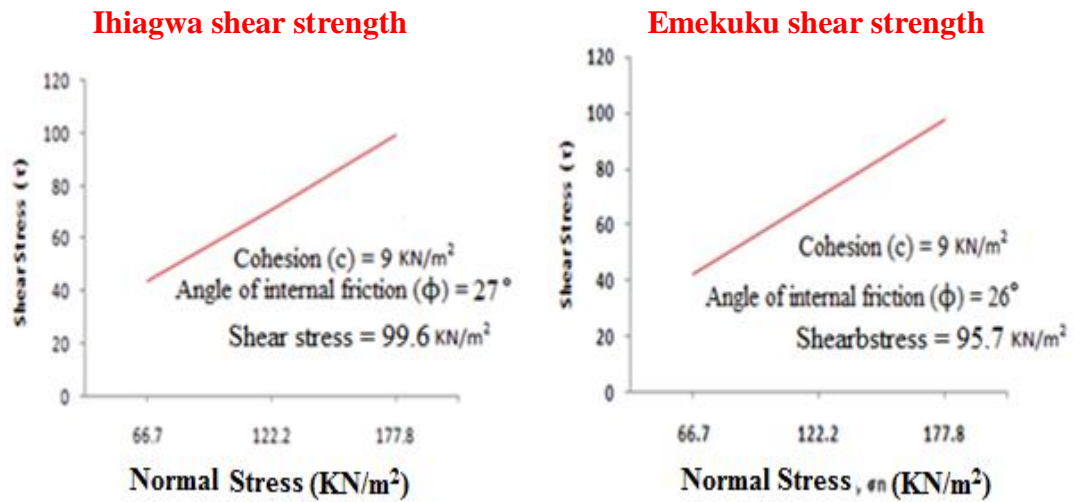

Figure 11: Showing graph of shear stress (τ) against normal stress, σ_n (KN/m²)

The model interpretation (VES 1 and 2) represent the depth, resistivity, lithology and color codes, corresponding to the interpretation of resistivity results (Figure 12).

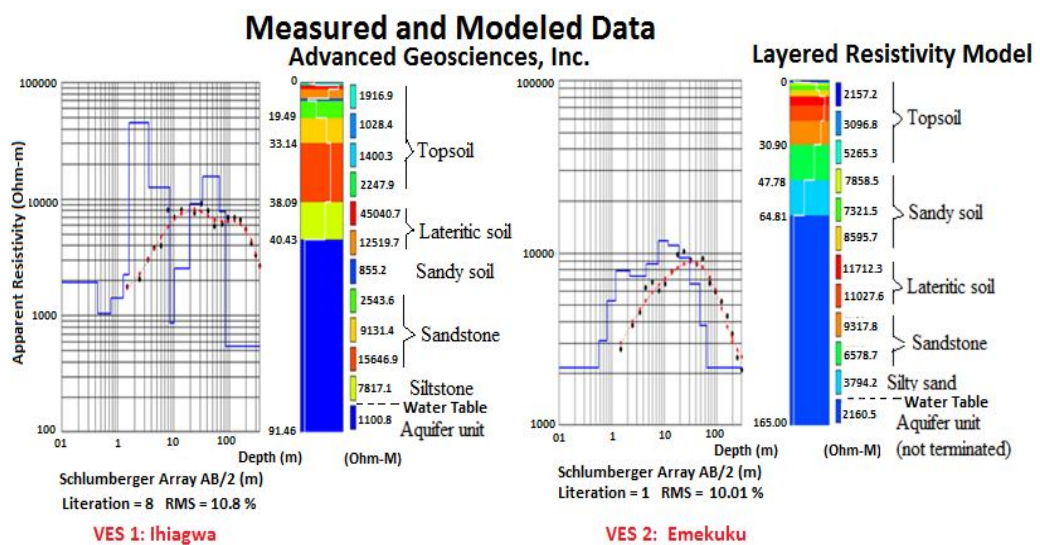

Figure 12: Showing 1-D Inversion Model Curves of Ihiagwa and Emekuku with 6 Lithologic Units

It emphasizes on resistivity response of the various geo-electric layers identified at Ihiagwa, its lithology is in order of topsoil, lateritic sand, silty sand, sandstone, sand and gravel beds.

The resistivity measurement at the road failed section of Ihiagwa study site shows that the area consists predominantly of silty sand, sandy lateritic soil after the topsoil. The sand-sandstone starts at a depth of 33.14 m and persist to 91.46 m (Table 2a). The lateritic soil overburden is adequate for road fill material, as the sandy subsurface presents a very good engineering characteristic for concrete and block molding.

Table 2a Showing resistivity result of Ihiagwa

Layer S/No.	Depth (m)	Resistivity (Ohm-m)	Lithology	Color
1	0.43	1916.9	Top Soil	Light Blue
2	3.62	45040.7	Lateritic soil	Red
3	10.31	855.2	Soil silty	Blue
4	19.49	2543.6	Soil sandy	Green
5	33.14	9131.4	Sandstone	Yellow
6	38.09	15646.9	Sandstone/Gravel bed	Brown
7	40.43	7817.1	Sandstone	Yellow
8	91.46	1100.8	Sand (Saturated)	Blue

The resistivity measurement of the Emekuku study site also shows that the area consists predominantly of sand- sandstone after the topsoil and the lateritic soil overburden, the sandstone starts at a depth of 30.89 m and persists to a depth of 165 m (Table 2b) similar to the Ihiagwa area, the lateritic soil overburden was adequate for roadfill, while the sand units also present good engineering characteristic for building, see appendix twelve for ASTM and British Standard for road fill and embankment construction.

Table 2b Showing resistivity result of Emekuku

Layer S/No.	Depth (m)	Resistivity (Ohm-m)	Lithology	Color
1	0.57	2157.2	Top Soil	Mixed Blue
2	0.82	3096.8	Soil silty	Blue
3	2.23	7858.5	Soil sandy	Light Yellow
4	7.66	8595.7	Soil sandy	Yellow
5	19.17	11712.3	Lateritic soil	Red
6	30.89	9317.8	Sandstone	Brown
7	47.78	6578.7	Sandstone	Green
8	64.81	3794.2	Sand	Light Blue
9	<165.00	2160.5	Sand (Saturated)	Blue

4.7 Result of Electrical Resistivity Measurement

Electrical resistivity measurements at the two sites show sandy topsoil 0.43 m and 0.57 m, followed by lateritic soil overburden to depth between 3.62 m and 19.17 m representing the borrow material. Below this depth is a sequence of sand, sandstone and gravel beds. Texture and moisture content of these material vary at several depth intervals, often very minor resulting to the model of up to 12 geo-electric layers at both Emekuku and Ihiagwa sites. Depth to water table at the two sites was mapped out and identified as shallow. A water table at depth of 40.43 m was found at Ihiagwa, and at Emekuku, the water table fluctuates between 47.78 m and 64.81.

In the presence of borrow pits with depths up to 20 m at some points, contaminants from drainage collection into the pits could migrate easily to the water table, thereby contaminating the groundwater. It is important to note that the two communities housing the investigated borrow pits depend on groundwater obtained from shallow wells for their drinking and other domestic uses. These shallow wells have average depth of 55 m, and according to (Nwachukwu et al., 2010), many of these shallow wells supply water of poor quality. There is growing cases of water related diseases in the areas particularly around Ihiagwa with high population density due to the presence of two higher institutions.

CHAPTER FIVE

SUMMARY OF BORROW PIT OPERATION AND RECLAMATION

5.1 *Preliminary Site Investigation*

Borrow pit site is to be professionally identified; preliminary testing of soil geotechnical properties should be carried. Geophysical methods such as the use of electrical resistivity method to map subsurface lithology of the site, including depth to, and thickness of the borrow material in place. Unless a site is certified scientifically, it should not be open for borrow pit excavation. Locating a borrow pit close to an existing or a proposed highway is not permissible. Borrow pit sites are preferred on escarpment with relatively higher elevation to the surroundings (Figure 13). Borrow pit should be located off residential and public areas, and must be accessible.



Figure 13: Cross – Section of a New Borrow Pit Site

5.2 *Pit Excavation*

Standard excavators must be used to remove the dark topsoil and expose the red earth borrow material. Usually the excavated topsoil is dumped at the side of the planned pit as spoil heap. Area of topsoil removal and arrangement of spoil heap will depend on the master plan and design of the borrow pit (Figure 14). Bench height, width, slope and total depth of pit must be

properly designed following information obtained from the preliminary site investigation (Figure 15).

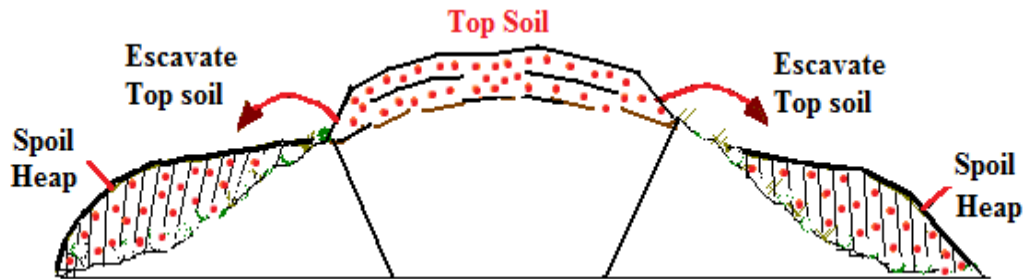

Figure 14: Excavation; showing removal of Top Soil to Spoil Heap

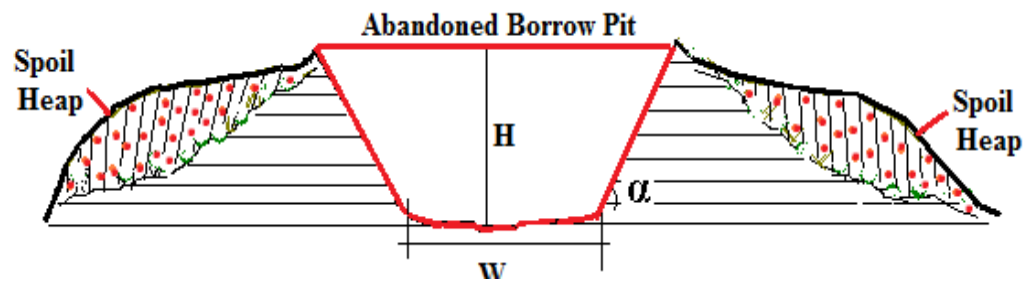

Figure 15: Mining Completed, Borrow Pit abandoned

H = Depth, W = Width, α = Angle of slope

5.3 Reclamation

Soon as borrow pit operation at a site is ended, and the project for which the borrow pit was opened is concluded, reclamation should commence immediately. This is important especially where no new road project is envisaged within the area and any future road project will not be at close proximity for borrowing from the site to be economical. Reclamation is commenced by moving the spoil heap back to the pit, followed by moving adjoining earth material to fill the pit (Figure 16).

Reclamation commences

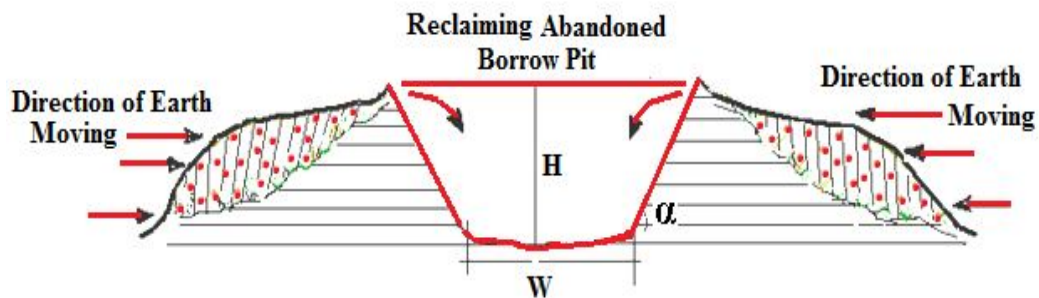

Figure 16: Arrow shows Direction of Earth moving using Bulldozer followed by Compaction using Compactor or Roller

This operation goes with compaction of the fill material using roller and treatment and testing the compacted earth to achieve the original soil characteristics and ground condition (Figure 17 and Plate 8).

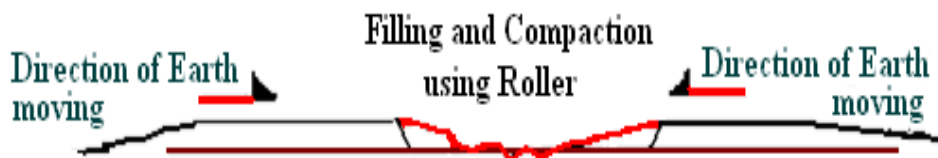

Figure 17: Testing Geotechnical Parameters to Conform with Previous Records



Plate 8: Reclamation Field Techniques

Finally, reclamation is accomplished by turning the reclaimed site green (Figure 18). This goes by planting grass and trees to improve the natural look of a reclaimed site and improve ecosystem services. Reclaimed site can be used for structural development or used as park for recreational activities.

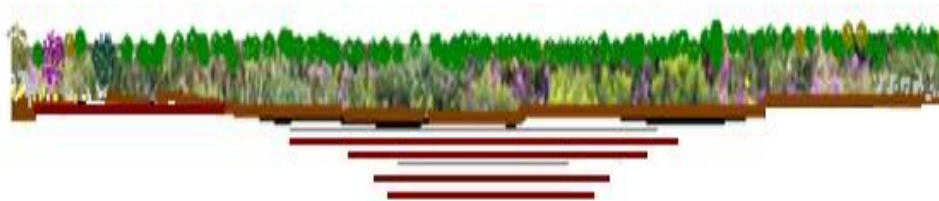

Figure 18: Reclaimed borrow pit site turned green; for farming, recreation parks, promote a self-sustaining environment which attracts wildlife and improve ecosystem services.

5.4 Recommendations

Following the environmental and Geotechnical site investigation carried out on the two abandoned borrow pits, these recommendations are made to bring about sustainable engineering practice in soil excavation in Nigeria. Firstly, operators of road side excavation and borrow pit should get the necessary permission from government such as ministry of Mines and Power. Secondly, proper geotechnical assessment should be carried out to avoid cases of trial pit that have eventually led to abandoned borrow pit. To do this, the use of soil resistivity measurement through Geophysical Instrumentation, which is a non-destructive or non-invasive methodology, should be employed before excavation. Thirdly, The Federal government through its relevant agencies like FEPA (Federal Environmental Protection Agency) and the Nigeria Environmental Regulatory Agency (NESREA) should ensure enforcement of rules and regulations which include sitting a borrow pit about 200 m from the

edge of a proposed highway and making sure thereafter that soil materials are removed from the borrow pit site, Appropriate reclamation of the borrow pit should be carried out immediately excavations have been completed. Abandoned borrow pit could be reclaimed and turned to recreational park where revenue is collected and remitted to the government. Operators and contractors should be prosecuted, if they fail to comply with the directives, designers and contractors of highways must use good expertise and conduct appropriate soil testing of engineering properties before engaging in the construction of highway to minimize the cases of highway failures.

5.5 *Regulatory Measures*

Review and enforcement of Nigeria mining laws is overdue, environmental protection is part and parcel of mining activity. Government should set up a Mine Environment Safety Agency (MESA) as a unit under the Federal Ministry of Environment. The present arrangement whereby staff from the Ministry of Mines may be assigned to visit mine sites is entirely a different assignment. MESA will have their office in the 36 States and Abuja, environmental concern in Nigeria should not end with the oil industry alone. Solid minerals including soil and sand excavation and groundwater exploitation by individuals across the country equally constitute serious environmental concerns threatening sustainable development in Nigeria. MESA is to be the government agency to enforce sustainable mining practice in Nigeria every state should have its MESA office reporting to both the State and Federal Environment Ministries. Mining activities of this type is contributing to rising environmental degradation in Nigeria which as at now has no record or statistics of these environmental degradations in all the states. In many cases across the country, abandoned borrow pits are converted to urban waste dumps, some becoming ponds where local communities go to fetch water. This, in no small measure, facilitates the spread of disease pathogens transport of contaminants to

groundwater system and aquifer pollution. In Imo state particularly and all over the county where citizens largely depend on shallow (substandard) private water wells as against unavailable or non functional public (government water wells), the health consequences of this practice is the heavy factor militating against economic growth and development. MESA will formulate guidelines based on environmental risk assessment for proper control measures and enforcement strategies.

5.6 Conclusion

Although there have been few attempts to quantify potential hazards from active and abandoned borrow pits, it is generally understood that the issue of abandoned borrow pits is a major environmental and geo-environmental problem for Government, the industry operators and the host communities where the abandoned borrow pits are situated. Lack of proper technical expertise has led to trial pit excavations which consequently brought about several abandoned borrow pits. Such abandoned borrow pits have resulted to Landslides, erosion and dumping of waste that have contaminated surface and ground water. Land degradation makes potential land buyers and developers to spend huge amounts of money in reclaiming excavated land which in turn slows down the pace of development of such excavated land. From soil analysis and Vertical Electric Sounding (VES), the highway failure along the Ihiagwa-Owerri highway can be attributed to lack of sustainable engineering practice. Laboratory soil analysis also revealed that the soil used for the construction of highway is part of the Benin Formation. Basically the sandy nature of the Formation makes it cohesionless and foretells why erosion problem around the study area is high.

REFERENCE

- Agostoni, R.J., 2000: Disaster prevention for sustainable development. Washington D.C. IDNDR And World Bank Pp 41-44
- Akpokodje, E.C., and Akaha, C.T., 2010: Gully Erosion geo-hazards in the South eastern Nigeria And Management Implications. *Scientia Africana*. Volume 10. Pp 101
- Allen, T. M., Christopher, B. R., Elias, V., and DiMaggio, J. D., 2001, Development of the Simplified Method for Internal Stability Design of Mechanically Stabilized Earth (MSE) Walls, WSDOT Research Report WA-RD 513.1, 108 pp.
- Anyanwu, E. E. and Ogbueke, N. V., “Design Considerations for Wind Energy Powered Water Pumping Facility for sites in Nigeria,” *Environ Protection Eng, JI* Vol.29. No. 2, 2003.
- Ardizzone, D.K., 2002: Abatement of Seismic hazards to life. *Action and Plans*. Pp 144-145
- Avbovbo, A. (1978). Tertiary Litho-stratigraphy of Niger Delta *Bull Amer. Ass Petrol Geol.* **62**, 295-305
- Ayodele, A., P. Oguntunde, A. Joseph, and M. de Souza Dias. 2009. Numerical analysis of the impact of charcoal production on soil hydrological behavior, runoff response and erosion susceptibility. *Rev. Bras. Cienc. Solo* 33:137–145. doi:10.1590/S0100-0683200900010001
- Bello, A.A. (2011). ”Influence of Compaction Delay on CBR and UCS of Cement Stabilized Lateritic Soil. *The Pacific Journal of Science and Technology*, Vol. 12, Number 2, 87-96
- Bloxam, E., 2011: Ancient quarries in mind. Pathways to a more accessible significant. *World Archaeology*. Volume 43. Pp 149-150

- Budhu. M. (2011) Soil mechanics and foundations, third edition, John Wiley & Sons, Inc., New Jersey,
- Chien S. I., and Tang Y. (2014), Scheduling highway work zones with genetic algorithm considering impact of traffic diversion; *Jl of Adv Transportation* Vol 48, (4) p. 287–303
- Coburn, T.H., and Hughes, B. L., 2000: The earth and land use planning. Pp102 Ellison, (2007): Soil erosion and deterioration in eastern Nigeria. *Nig. geography jl* Vol. 8(1) Pp 33-44
- Etuk, E.E., and Ukpabi, N., 2008: Structural Evolution, Magnetism and Effect of Hydrocarbon
- Ezezika, O. C., and Adetona, O., 2011: Resolving the gully erosion problem in Southeastern Nigeria: Innovation through public awareness and community-based approaches; *Journal of Soil Science and Environmental Management* Vol. 2(10), Pp 286-290
- Gadzama, E.W. (2009). "Evaluation of Soil Samples From Federal University of Technology, Yola Site" *Nigerian Journal Of Engineering*. 15(2): 80-88.
- Guzzetti F., Carrara A., Cardinali M. & Reichenbach P., (1999), Landslide hazard evaluation: an aid to a sustainable development. *Geomorphology*, 31, 181-216.
- Guzzetti F., Crosta G., Detti R. & Agliardi F., (2002), STONE: a computer program for the three-dimensional simulation of rock-falls. *Computers & Geosciences*, 28: 9, 1079-1093.
- Hansen A. Landslide hazard analysis. In: Brunsden D. & Prior D.B. (eds.), *Slope Instability*, John Wiley and Sons, New York, 1984, 523–602.
- Head KH (2010). "Manual of Soil Lab Testing": Soil classification and Compaction test 1:198.
- Hewitt, K., 1992: Landslide assessment and mitigation. MIT Press. Pp177.

- Hudec P.P, Simpson W.F, Akpokodje, E.G and Umenweke, M.O (2006): Processing of the Eighth Federal Inter-Agency Sedimentation Conference (8thFISC). Pp 66
- Magmatism and Effects of Hydrocarbon Maturation in Lower Benue Trough, Nigeria Pacific Journal of Science and Technology. Vol. 9. Pp 526- 532
- Mawdesley, M. J., Askew, W. H. and Al-Jibouri, S. H. (2004), Site layout for earthworks in road projects, JI of Engineering Construction and Architectural Management, 11(2), pp 83-89.
- NGSA; Nigerian Geological Survey Agency, Map and survey data report (2004)
- Nigeria Mining Act (1992); Current version for 1 Feb 2015 to date (accessed 26 June 2015 at: <http://www.legislation.nsw.gov.au/xref/inforce/?xref=Type%3Dact%20AND%20Year%3D1992%20AND%20no%3D29&nohits=y>)
- Nwachukwu, M. A., Osoro E. (2013). Assessment of environ hazards; linking borrow pits, gully erosion, and road failure; J of geotech Eng and Construction Tech. Vol. 4(6), pp. 199-210
- Nwachukwu, M.A, Huan F (2012). “Environmental hazards and sustainable development of rock quarries lower Benue trough Nigeria.” Oida Int. J. Sustain. Dev. 5(6):51-68.
- Nwachukwu, M.A, Feng H, Amadi, M.I., Umunna, F.U. (2010). The Causes and the control of Selective Pollution of Shallow Wells by Coliform Bacteria, Imo River Basin Nigeria Water Qual Expo Health (2010) 2: 75–84; DOI 10.1007/s12403-010-0025-4
- Nwajide, C.S, Hoque M (1979). Gullying process in Southeastern Nigeria Field 2(44):64-74.
- Obiefuna, G. I., and Adamu, J., 2011: Geological and Geotech Assessment of Selected Gully Sites in WuroBayare Area NE Nigeria; Research JI of Environ and Earth Sc. 4(3): 282-302

- Omosanya, K.O., and Ajibade, M.O., 2011: Environmental impact of quarrying on Otere village, Odeda, Southwestern Nigeria. *Ocean J of Applied Sciences* 4 (1), 2011. Pp 22-25.
- Pimentel, G.A., and Parasunama, J., 2009: Soil material for Civil engineering construction *Journal of Soil Horizon*. Pp 67-68
- Pistocchi A (2003). "A multicriteria geographical approach to environmental impact assessment of open pit quarries." *Int. J. Surf. Min. Reclam. Environ.* 17(4):213-216.
- Sabatini, P.J., 2002: "Evaluation of Soil and Rock Properties," *Geotechnical Engineering Circular*, No. 5, Federal Highway Admin, U.S. Dept of Transport, Washington, DC. Pp 206
- Shah, R. K. and Dawood, N. (2011), "An innovative approach for generation of a time-location plan in road construct projects", *Jl of Construction Managt and Econs*, 29(5), pp 435-448
- Uma, K. O., and Egboka, B.C.E.(1986). Water resources of Owerri and its environs, Imo State, Nigeria, *J. Min. Geol* 22, 57–64.
- UNDRO: UN Disaster Relief Organisation (1982), *Disaster prevention and mitigation: a compendium of current knowledge* vol. 8. Sanitation aspects Varnes, D.J., 1978: Slope movement and type of process: in landslide analysis and control *Nat. acad of sc.* Pp 202.
- Venkata MS, Takuro K, Takeru O, Robert AK, Yoshihisa S (2006). Bioremediation technologies for treatment of PAH-contaminated soil and strategies to enhance process efficiency. *Rev. Environ. Sci. Biotechnol.* 5, 347–374.

APPENDIX 1

Test type: Grain Size Analysis

Sample A (Laterite)

Location 1: Ihiagwa

Table 1: showing grain size analysis of abandoned borrow pit

Sieve size (mm)	Mass Retained (g)	Mass Passing (g)	% Passing
2.0	0.8	99.2	99.2
1.18	6.6	92.6	92.6
0.85	11.0	81.6	81.6
0.600	12.9	68.7	68.7
0.425	10.4	58.3	58.3
0.300	16.0	42.3	42.3
0.15	17.0	25.3	25.3
0.075	1.9	23.4	23.4
Pan	0.0	23.4	

APPENDIX 2

Test type: Grain Size Analysis

Sample B (Yellow sand)

Location 1: Ihiagwa

Table 2: Showing grain size analysis of abandoned borrow pit

Sieve size (mm)	Mass Retained(g)	Mass Passing (g)	% Passing
2.0	12.8	98.7	88.5
1.18	10.2	88.5	79.4
0.85	11.5	77.0	69.1
0.600	22.6	54.4	48.8
0.425	18.8	35.6	31.9
0.300	25.3	10.3	9.2
0.15	8.6	1.7	1.5
0.075	1.2	0.5	0.5
Pan	0.1	0.4	

APPENDIX 3

Test type: Grain Size Analysis

Sample C (White sand)

Location 1: Ihiagwa

Table 3: Showing grain Size analysis of abandoned borrow pit

Sieve size (mm)	Mass Retained (g)	Mass Passing (g)	% Passing
2.0	10.6	89.4	89.4
1.18	15.5	73.9	73.9
0.85	17.9	56.0	56.0
0.600	17.3	38.7	38.7
0.425	17.3	21.4	21.4
0.300	15.7	5.7	5.7
0.15	5.1	0.6	0.6
0.075	0.4	0.2	0.2
Pan	0.1	0.1	0.1

APPENDIX 4

Test type: Grain Size Analysis

Sample A (Laterite)

Location 2: Emekuku

Table 4: Showing grain size analysis of abandoned borrow pit

Sieve size (mm)	Mass Retained (g)	Mass Passing(g)	% Passing
2.0	0.5	99.5	99.5
1.18	3.8	95.7	95.7
0.85	6.4	89.3	89.3
0.600	7.9	81.4	81.4
0.425	6.9	74.5	74.5
0.300	12.3	62.2	62.2
0.15	9.9	52.3	52.3
0.075	0.7	51.6	51.6
Pan	0.0	51.6	

APPENDIX 5

Test type: Grain Size Analysis

Sample B (Yellow sand)

Location 2: Emekuku

Table 5: Showing grain Size analysis of abandoned borrow pit

Sieve size (mm)	Mass Retained(g)	Mass Passing(g)	% Passing
2.0	6.8	102.2	93.8
1.18	18.0	84.2	77.3
0.85	34.1	50.1	46.0
0.600	28.1	22.0	20.2
0.425	10.1	12.0	11.0
0.300	5.8	6.2	5.7
0.15	4.7	1.5	1.4
0.075	0.9	0.6	0.6
Pan	0.1	0.5	

APPENDIX 6

Test type: Grain Size Analysis

Sample C (White sand)

Location 2: Emekuku

Table 6: Showing grain Size analysis of abandoned borrow pit

Sieve size (mm)	Mass Retained(g)	Mass Passing(g)	% Passing
2.0	7.7	94.7	92.3
1.18	9.7	85.2	83.0
0.85	15.3	69.9	68.1
0.600	20.0	49.9	48.6
0.425	17.3	32.6	31.8
0.300	21.4	11.2	10.9
0.15	10.2	1.0	9.8
0.075	0.8	0.2	0.2
Pan	0.1	0.1	

APPENDIX 7

COMPACTION TEST

Ihiagwa sample

Table 7: Showing Bulk Density result sample at Ihiagwa site

Trial No.	1	2	3
Mould + compacted soil (g)	6200	6600	6500
Mould (g)	4500	4500	4500
Compacted soil (g)	1700	2100	2100
Volume of mould (cm ³)	1000	1000	1000
Bulk density (Mg/m ³)	1.70	2.100	2.00

Table 2.3: Showing Moisture content and dry density determination result

Trial No.	1	2	3
Can identification	30	10	23
Can + wet soil (g)	75.9	50.5	51.5
Can +dry soil (g)	72.3	46.3	46.0
Can (g)	19.4	16.1	17.3
Dry soil (g)	52.9	30.2	528.7
Water (g)	3.6	4.5	5.5
Water Content (w%)	6.8	13.9	19.2
Dry density (Mg/m ³)	1.59	1.84	1.68

Result: Maximum Dry Density (M.D.D) = 1.84 (Mg/m³)

Optimum Moisture Content (O.M.C) = 13.9 %

APPENDIX 8

Table 8: Ihiagwa schlumberger measurement data sheet

Data #	V (mV)	I (mA)	MN (m)	AB/2 (m)	Ohm-m
1	21800.000	100	1.000	1.500	1369.73
2	20000.000	100	1.000	2.500	3769.91
3	11000.000	100	1.000	3.500	4146.90
4	4000.000	100	1.000	4.500	2513.27
5	2900.000	100	1.000	6.000	3257.05
6	1900.00	100	1.000	8.000	3805.25
7	2000.000	100	1.000	10.500	6911.50
8	584.768	100	1.000	14.000	3596.13
9	4360.699	100	7.000	14.000	3596.13
10	1900.000	100	7.000	18.000	2658.35
11	1800.000	100	7.000	24.000	4554.19
12	1800.000	100	7.000	32.000	8173.30
13	1400.000	100	7.000	42.000	11006.57
14	486.116	100	7.000	55.000	6572.87
15	2070.763	100	28.000	55.000	6572.87
16	1100.000	100	28.000	75.000	6700.46
17	500.000	100	28.000	95.000	4953.06
18	400.000	100	28.000	125.000	6924.52
19	300.000	100	28.000	160.000	8550.97
20	114.643	100	28.000	200.000	5119.93
21	434.593	100	100.000	200.000	5119.93
22	400.000	100	100.000	250.000	7539.82
23	200.000	100	100.000	300.000	5497.79

APPENDIX 9

Table 9: Emekuk schlumberger measurement data sheet

Data #	V (mV)	I (mA)	MN (m)	AB/2 (m)	Ohm-m
1	13870.000	100	1.000	1.500	871.48
2	11030.000	100	1.000	2.500	2079.11
3	10560.000	100	1.000	3.500	3981.03
4	9070.000	100	1.000	4.500	5698.85
5	4020.000	100	1.000	6.000	4514.94
6	2800.000	100	1.000	8.000	5607.74
7	4250.000	100	1.000	10.500	14686.95
8	1729.768	100	1.000	14.000	10637.50
9	12899.128	100	7.000	14.000	10537.50
10	9550.000	100	7.000	18.000	13361.70
11	4030.000	100	7.000	24.000	10196.32
12	1720.000	100	7.000	32.000	7810.04
13	1000.000	100	7.000	42.000	7861.84
14	385.667	100	7.000	55.000	5214.68
15	1642.868	100	28.000	55.000	5214.68
16	1010.000	100	28.000	75.000	6152.24
17	690.000	100	28.000	95.000	5835.22
18	710.000	100	28.000	125.000	12291.02
19	250.000	100	28.000	160.000	7125.81
20	176.430	100	28.000	200.000	7879.36
21	668.821	100	100.000	200.000	7879.36
22	260.000	100	100.000	250.000	4900.88
23	140.000	100	100.000	300.000	3848.45

APPENDIX 10

Table 10: showing classification by particle size (Based on BS 1377:1975)

PARTICLE SIZE	DESIGNATION		TEST PROCEDURE
≥ 200	Boulders		MEASUREMENT OF SEPARATE PIECES
60	Cobbles		
20	Coarse	GRAVEL	SIEVE ANALYSIS
6	Medium		
2	Fine		
0.6	Coarse	SAND	
0.2	Medium		
0.06	Fine		
0.02	Coarse	SILT	SEDIMENTATION ANALYSIS
0.006	Medium		
0.002	Fine		
And less		CLAY	

The source of the table is from M.A Head (1984)

APPENDIX 11

Table 11: showing Comparison of system for classifying particle size ranges of soil

USA ASTM D422

0.0.02	0.06	2			60mm		
Colloid			Fine	Medium	Coarse		
Clay		Silt	Sand			Gravel	cobbles
Parti size 1	5	75	425µm	2.00	4.75	76.2mm	
Sieve designation	NO200	NO40	NO10	N04	3inch		

Great Britain BS 1377 1975

	Fine	Med	Coarse	Fine	Med	Coarse	Fine	Med	Coarse		
Clay	Silt			Sand			Gravel			Cobbles	boulders
Part size 2	2	6	20	60	200	600µm	2	6	20	60	200mm

APPENDIX 12

Table 12: Showing general guide for selection of soil performance on basis of
anticipated embankment performance

HRB CLASSIFICATION	VISUAL DESCRIPTIO	MAX. DRY WT RANGE (PCF)	OPTIMUM MOISTURE RANGE (%)	ANTICIPATED EMBANKMENT PERFORMANCE
A.1.a	Granular material	115-142	7-15	Good to excellent
A.1.b				
A.2-4	Granular material with soil	110-135	9-18	Fair to excellent
A.2-5				
A.2-6				
A.2-7				
A.3	Fine sand and sand	110-115	9-15	Fair to good
A.4	Sandy silt and silt	95-130	10-20	Poor to good
A.5	Elastic silt and clay	85-100	20-35	Unsatisfactory
A.6	Silt clay	95-120	10-30	Poor to good
A.7-5	Elastic silty clay	85-100	20-35	Unsatisfactory
A.7-6	Clay	90-115	15-30	Poor to fair