

Time: 3 Hours

Semester: Harmattan

Course Code: ENG 213

Instruction: Answer all questions

1.0 Determine the forces acting on the members of the truss shown in Figure 1 the ends of the truss rest on smooth surfaces. Take the reactions at the left ends

$R_1$  as 17.75 k N, and the reaction at the right end

$R_2$  as 19.25 k N.

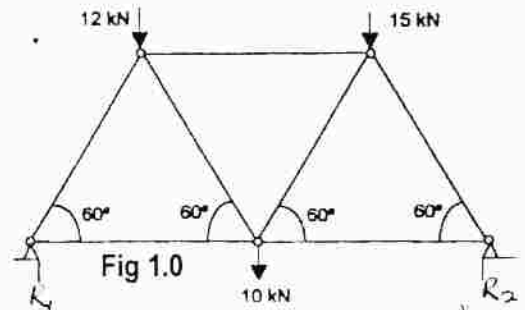

2.0 Determine the resultant of the four forces and one couple which act on the plate shown in the fig 2 below.

3.0 A tension T of magnitude 10 k N is applied to the Cable attached to the top of A of rigid mast and secured to the ground at B. Determine the moment  $M_z$  of T about

The z-axis passing through the base O. See fig 3.0

4.0 Calculate the moment of 90 N force about a Point O for the condition that  $\theta = 30^\circ$ .

Also find the value of  $\theta$  for which

the moment is zero and maximum respectively. See fig 4.0

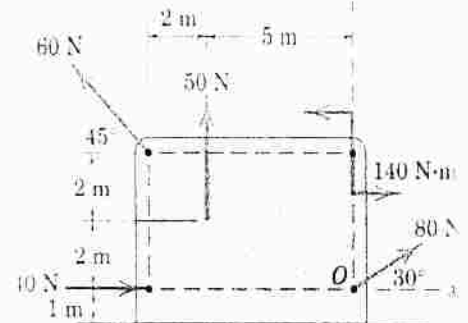

Fig 2.0

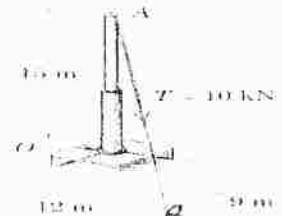

Fig 3.0

5.0 A force of 10 kN acts from the origin through a point (2, 1, 2) m. determine the rectangular components of this force.

What is the component of this force along a line OL passing through the origin and point (1, 1, 1) m.

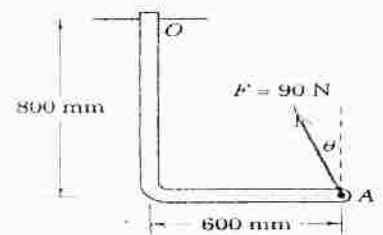

Fig 4.0