

Recombinant Phosphoinositide-3-Kinase C2 β C2 Domain Molecules

Banigo, Alma Tamunonengiofori* Azeez, Taofik Oladimeji

Department of Biomedical Technology, Federal University of Technology, P. M. B. 1526, Owerri, Imo State, Nigeria

Abstract

Recombinant DNA domain remains a dependant of effective use of recombinant proteins in many applications but its production remains an area of concern due to DNA vector and production path. This work is aimed at studying the generation and replication of the recombinant DNA molecule using PI3K C2 β C2 domain and glutathione s-transferase (GST) which expressed in pGEX-2T vector. The molecular cloning technique was employed to generate a recombinant DNA molecule. PI3K C2 β C2 domain of isoform PI3K C2 β belonging to class PI3K C2 of Phosphoinositide-3-Kinase (PI3K) family was used and the effective digestion of pGEX-2T vector was studied using restricted enzymes (RE) of *EcoR* I and *Sma* I with binding partners location. The ligated product of recombinant DNA was obtained after successful doubled digestion of pGEX-2T vector. The best transformation of competent bacterial cells was obtained at molar ratio of 5:1 for RE digested vector insert DNA and vector DNA. The recombinant DNA can be employed may be used in treatment of non – communicable diseases such as cancer and diabetes.

Keywords: Recombinant DNA molecule, Phosphoinositide-3-Kinase (PI3K), PI3K C2 β C2 domain, Restriction enzyme, Ligation

1. Introduction

Recombinant DNA molecules are living entities created when at least two DNA molecules from different species bind together in a specific host [1] by a process known as *molecular cloning*. This process is usually employed directly after amplification and replication of the DNA sequence of the gene was performed by using polymerase chain reaction (PCR) [2 - 5]. The recombinant DNA molecules are of utmost importance to science and medicine. It can be used for the diagnosis, prevention or treatment of some diseases such as diabetics, AIDS or some types of cancer; production of hormones, vaccines or antibiotics; application of gene therapy; forensic research and experimental studies [6 - 10]. The synthesis of recombinant DNA sequence of gene especially PI3K C2 β C2 domain remains an area of concern for biomedical professionals so as to enhance health care delivery. The enzyme donor as reported in [11] is located at the C terminus that is attached to the PI3K core structure involved in Ca²⁺ dependent or Ca²⁺ independent phospholipid membrane binding, thereby, mediate protein-protein interaction [12]. The enzyme donor is a portion of the second isoform of the second class belonging to the family of enzyme, PI3K. The size of this domain is about 126 amino acid residues and bears 378 base pairs. Arcaro et al. [13] reported that PI3K C2 β C2 domain may bind Ca²⁺ with low affinity when compared to PI3K C2 α domain of synaptotagmin and its absence could result in raising the activity of lipid kinase. Some other domains present in this isoform also tend to be involved in protein-protein interaction as well as fuse to membrane lipids [14]. The importance of PI3K C2 β such as membrane trafficking [11], cell migration on some epithelial lines [15] and differentiation of HL-60 hematopoietic cells by retinoic acid [16] cannot be underestimated, yet there is still limited report on the activities carried out by PI3K C2 β C2 domain only. The vector, pGEX-2T used for molecular cloning consists of bacterial plasmid of about 4948 base pair with multiple cloning sites as well as a selectable marker, ampicillin [17, 18] as shown in Figure 1.

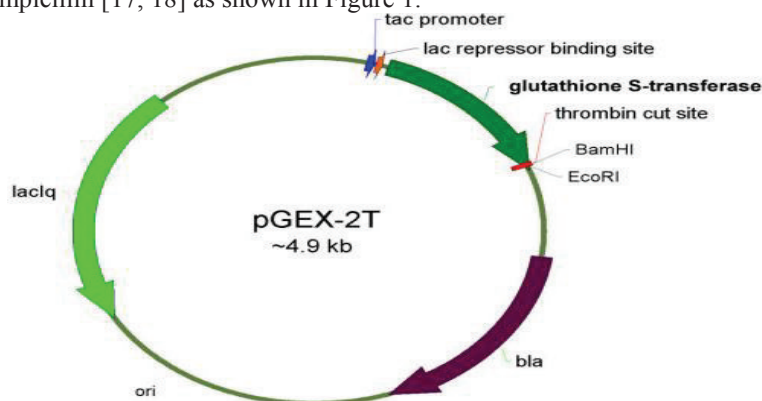

Figure 1: A schematic diagram of pGEX-2T vector [17, 18].

The circular cloning vector generates high level intracellular expression of whole genes or gene fragments

when bound to *Schistosoma japonicum* Glutathione S-transferase (GST) [18]. GST is a 26kDa protein usually expressed in *Escherichia coli* (*E. coli*) with full enzymatic activity and GST fusion system is mostly employed to purify and detect fusion proteins already produced in *E. coli*. Amplification of the enzyme donor and gene of interest has already been reported by Banigo and Azeez [11]. Effective generation and utilization of GST fusion protein required a preliminary step of genetic engineering which will apparently be used to determine some binding partners; detect some diseases associated with the gene and also develop better therapeutic tools. Furthermore, researchers have reported the performance of proteins such as DNA-protein interaction [19], protein-protein interaction [20 - 22], and the production of vaccines [23, 24]. This work is aimed at generating and replicating the recombinant DNA molecule using PI3K C2 β C2 domain and glutathione s-transferase (GST) expressed in pGEX-2T vector.

2. Materials and Methods

Recombinant DNA technology utilizes some biological agents such as DNA insert, cloning vector DNA, restriction endonucleases, DNA ligases, DNA polymerase and host organism to achieve its goal.

2.1 Materials for Restriction Enzyme Digestion

Restriction enzymes (*Sma* I and *E.coR* I enzymes), Buffer A, autoclaved Milli-Q-purified water and DNA samples were used for restricted enzymes (RE) digestion of pGEX-2T vector and vector insert as listed in Table 1.

Table 1: Materials needed for RE digestion

Materials	pGEX-2T vector	Vector DNA insert JD
Buffer A	3 μ l	3 μ l
Autoclaved Milli-Q-purified water	20, 22, 24 μ l	20/22 μ l
pGEX-2T vector DNA	3 μ l	-
DNA insert	-	5 μ l
<i>Sma</i> I and <i>E.coR</i> I enzymes	4 μ l total	1 μ l each
Total volume	30 μ l	30 μ l

2.2 Restriction enzyme digestion of DNA insert and pGEX-2T vector

The purified amplicons, JD 89/88, 90/88 and 91/88 of PI3K C2 β C2 domain obtained from Biomedical Laboratory, University of Bedfordshire apparently generated by [11] were digested with both *Sma* I and *E.coR* I restriction enzymes (RE). Buffer A was used for *Sma* I and *E.coR* I. The master mix comprising of the purified amplicon (DNA insert), Buffer A and Autoclaved Milli-Q-purified water was mixed with both enzymes or without the enzymes (negative control) in their right proportions and centrifuged at 13,200rpm for 30s to have a complete reaction. The master mix containing the pGEX-2T tagged as 438 and 449 samples were incubated at 25°C for 90mins and at 37°C for 60mins, respectively. Afterwards, the RE digested PCR products were analysed using 1% Agarose gel.

2.3 Purification of PCR products after restriction enzyme digestion

The double digested amplicons (DNA inserts) were purified using QIAquick PCR purification kit (QIAGEN Inc., Valencia, CA) as described by Banigo and Azeez [11]. The Buffer PB containing guanine chloride, denaturant, protein detergent and DNA inserts were mixed, placed into a QIAquick column, and centrifuged at 13,200 rpm for 50s to bind DNA. The Buffer PE was aliquoted into the QIAquick column and centrifuged at 13,200 rpm for 50s to elute DNA. Fluid was discarded and the QIAquick column was placed in a fresh tube. The product was centrifuged at 13,200 rpm for 50s and eluted with autoclaved Milli-Q-purified water. The purified double digested amplicons was analysed using 1% Agarose gel.

2.4 Gel extraction of RE digested pGEX-2T vector fragment and purification of DNA

The digested DNA fragments seen on the agarose gel were isolated, excised with a brand new scalpel on a Bench top 3UVTM trans-illuminator and transferred into tubes. The QIAquick Gel extraction kit Protocol (QIAGEN Inc., Valencia, CA) was used for extraction and purification of the double digested vector DNA fragment. The gel slice was weighed in the micro - centrifuge tube. The excised gel and Buffer QG in the ratio of 3:1 were added, incubated at 50°C for 10 mins to dissolve the gel completely and confirmed that the colour of the solubilised gel samples was yellow. Isopropanol was added to the sample in the tubes, then transferred into a QIAquick column and centrifuged for 1min to bind DNA. The soluble DNA was extracted and analysed using 1% Agarose gel.

2.5 DNA Ligation of both pGEX-2T vector DNA and DNA insert

The DNA ligation was obtained from the combination of constituents presented in Table 2. Control sample

comprised of the vector only and ligase (15µl without the insert). The reaction mix was incubated at 16⁰C overnight in a SANYO incubator supplied by Patterson Scientific. The cleavage of digested pGEX – 2T vector and ligation of vector DNA and DNA insert are shown in Figure 2.

Table 2: The constituents of DNA ligation

Materials	Volume (µL)
RE digested vector DNA	1.0
RE digested vector insert DNA	5.0
T4 DNA ligase buffer (10x)	2.0
T4 DNA ligase	1.0
PEG 4000 solution (50%)	2.0
Autoclaved Milli-Q-purified water	9.0
Total volume	20.0

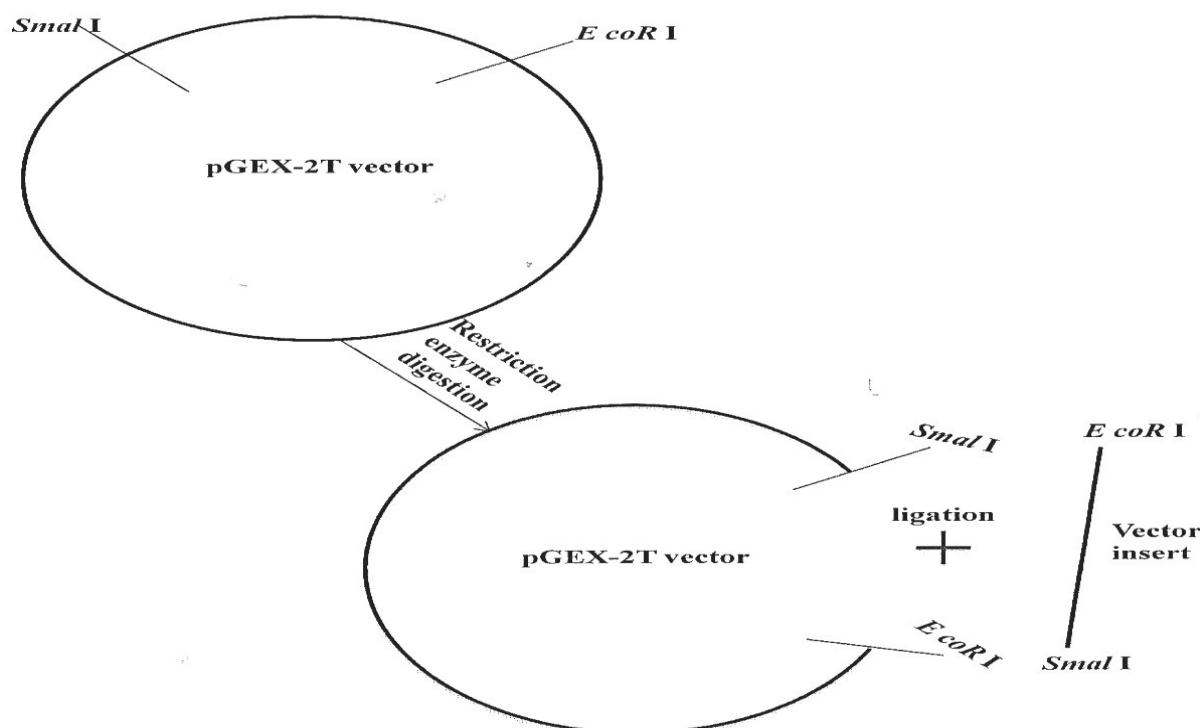

Figure 2: The cleavage of pGEX-2T vector and ligation of the vector DNA and DNA insert (PI3K C2β C2 domain) at specific restriction sites.

2.6 Transformation of competent XL-1 cells.

Competent XL-1 cells at 80⁰C was obtained from Biomedical Laboratory, University of Bedfordshire and thawed on ice. Luria Broth (LB) agar plates containing antibiotic were warmed up in the incubator at 37⁰C after being removed from 4⁰C. 5µl of recombinant DNA molecule (pGEX-2T vector + DNA insert) and 100µL of competent cells were mixed using a sterile technique in a centrifuge tube shaker and placed on ice for about 15mins. Terrific Broth (TB) without antibiotics was added to each tube containing the transformation mixture and incubated at 37⁰C for 60mins to allow bacteria grow. The samples were centrifuged for 1min at 13,000rpm and some volumes of supernatant was aspirated leaving about 50µL medium above the pellet. The cells were re-suspended and spread around the agar plates containing antibiotics to create a bacterial lawn and incubated at 37⁰C for 16 hrs.

3. Results and Discussion

Figure 3 shows the RE digestion of the vector with a single enzyme, *EcoR I* and pGEX-2T. It can be observed that the Lane 1 tagged as SM (selectable marker) has bands of 1Kb (Kilo base) molecular weight marker. The pGEX-2T tagged with 438 and 449 prepared with restricted enzyme and buffer A represent Lane 2 and 3, respectively, formed a bright and sharp band at 5kb but not properly digested. The Lane 4 and 5 which represent pGEX-2T of 438 and 449 without *EcoR I* but with buffer A, respectively, show a faint band formation at 3kb.

This indicated that restricted enzyme *EcoR* I aids the digestion of pGEX-2T due to increase in band width. The pGEX-2T without any reagent and restricted enzymes represented by lane 6 and 7, respectively, shows no formation of band. The absence of band in lane 6 and 7 may be attributed to the absence of buffer A and restricted enzyme activity.

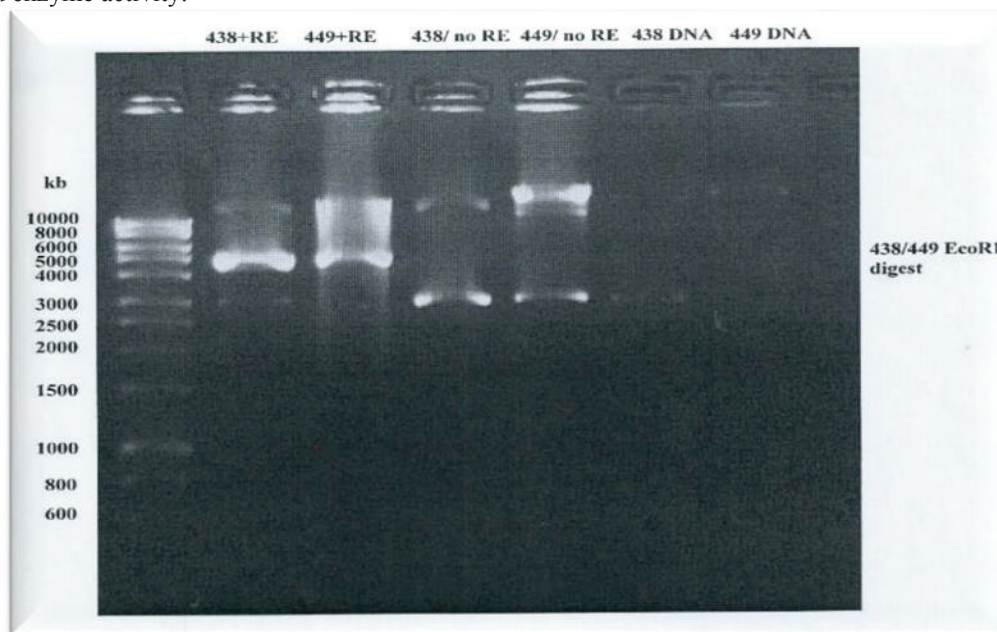

Figure 3: Single digestion of two pGEX-2T vector preparations with *E.coR* I run on 1% agarose gel.

After examination of single digestion of pGEX-2T vector with *EcoR* I, the result shows the important of restricted enzyme (*E.coRI*) and buffer A in the digestion. The effect of both enzymes in digestion of pGEX-2T vector is presented in Figure 4. The *EcoRI* and *SmaI*, respectively, did not properly digest the pGEX-2T vector at 5kb as observed in lane 2 and 3 of Figure 4. This may be attributed to impurity of pGEX-2T vector. *EcoRI* gave a sticky end as presented in Figure 5 while *SmaI* gave a blunt end as shown in Figure 6. Lanes 2 and 3 represent control samples of pGEX-2T containing a single enzyme of *E.coRI* and *SmaI*, respectively. However, the use of combination of two restriction enzymes (*EcoRI* and *SmaI*) for breaking down of pGEX-2T vector or amplicons is called *double digestion* and both REs used, gave a clear cut of vector DNA at 5kb. This may be attributed to the effectiveness and synergistic effect of double restriction enzymes as *Sma* I worked at 25°C for 90mins and *E.coR* I worked at 37°C for the optimal digestion activity. Lanes 4, 5 and 6 represent the pGEX-2T vector with both enzymes, show a clear cut product and sharp band at 5kb compared to lanes 2 and 3, respectively. This indicated the master mix with both REs gave a less product digestion.

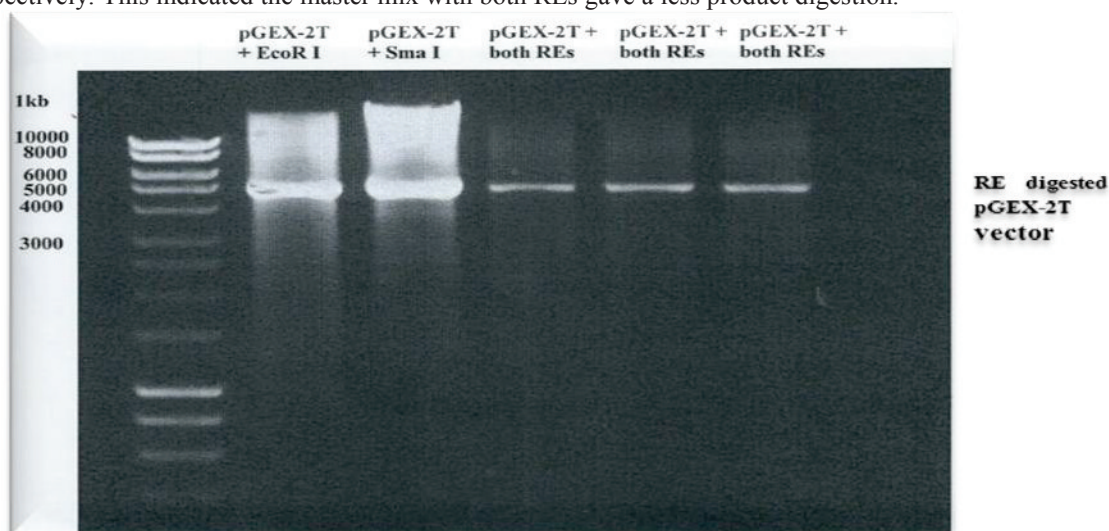

Figure 4: Effect of double digestion of pGEX-2T vector using *EcoR* I and *Sma* I REs on 1% agarose gel.

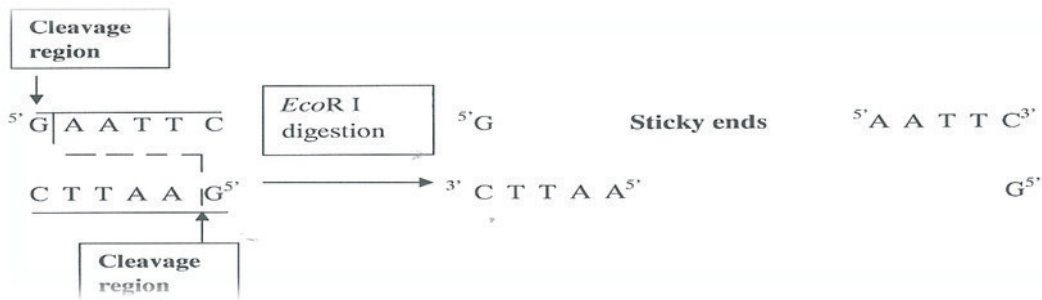

Figure 5: Cleavage of DNA with *EcoR I*

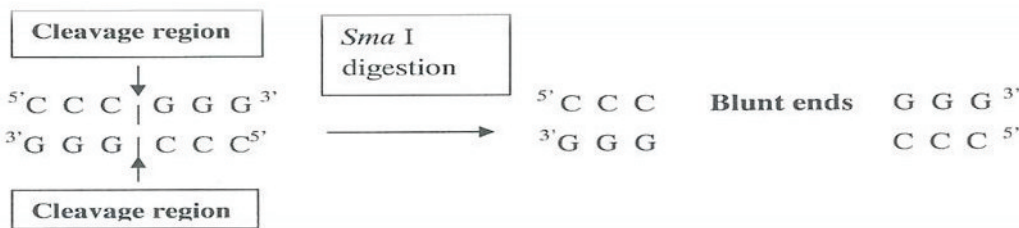

Figure 6: Cleavage of DNA with *Sma I*

Figure 7 shows the purified double digested PCR and pGEX-2T vector. Figure 7 and 8 clearly explain the sequence of the amplicons inserted into the plasmid in one direction, as both REs were adjacent to each other in the polylinker region. Lanes 2, 3 and 4 show clear PCR products (containing the different primers) at ~400bp and the estimated concentration of their DNA is between 80 - 100ng, whereas lane 5 contains the pGEX-2T vector of about 5kb in size with clear DNA of about 20ng of DNA concentration as compared to the latter. The essence of purifying pGEX-2T vector DNA, is to remove debris from single copy of genomic DNA isolated from an infected organism in the products. The variation in thickness of the DNA bands of PCR primers may be attributed to the level of concentration of purity of the DNA product. The thicker the band, the higher the concentration of the impurity in the DNA and vice versa. However, the purified double digested pGEX-2T obtained exhibits high purity. This is in agreement with the report of Banigo and Azeez [11].

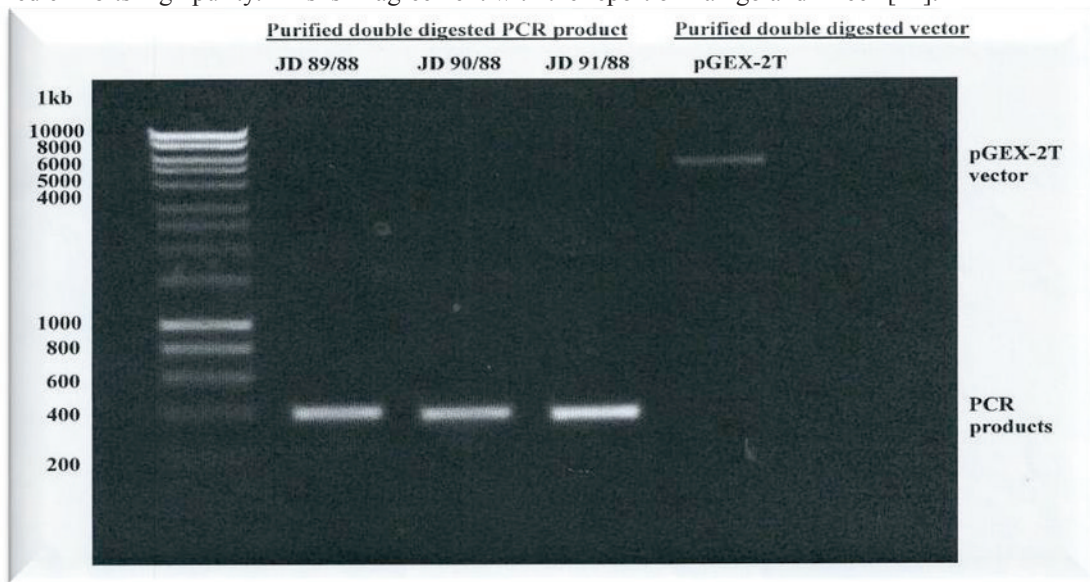

Figure 7: Purified DNA products obtained from the RE digestion of PCR products (DNA insert) and pGEX-2T vector with *EcoR I* and *Sma I* on 1% agarose gel.

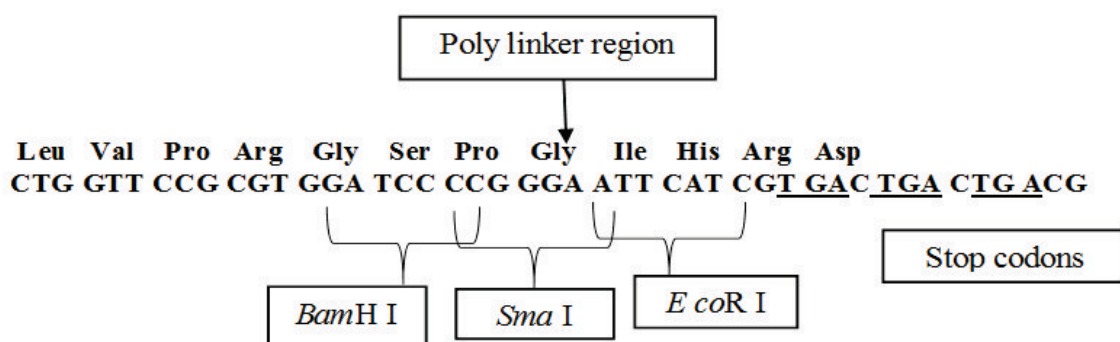

Figure 8: Location of the polylinker region between Sma I and EcoR I restriction enzymes sites in pGEX-2T vector

After a successful double digestion of both pGEX-2T vector and vector insert, blunt - end ligation protocol from (Thermo Scientific, Lot 00102127) was employed to aid ligation. All the required reagents and temperature at the specific time were used during ligation. It was expected that the sticky end would ligate faster due to compatibility than blunt end. Essential co-factors in the DNA ligase such as ATP supplied energy to aid ligation. The result obtained from ligation could only be ascertained after transformation and sequencing was achieved.

Figure 9 shows the transformation of competent XL-1 cells with the ligated product. The absence of colony was observed on the LB Agar + Ampicillin plate after several repeats of transformation of XL-1 with ligated products. Re-checking of all reagents and procedures was done starting from the temperature used to shock the cells at 42⁰C, fresh ampicillin and purified DNA products to the molar ratio. Poor transformation of competent XL-1 cells with the ligated product was obtained for molar ratio of 3:1. This may be attributed to incorrect molar ratio of both vector insert DNA and vector DNA used as reported by Williams et al [25]. The ratio 5:1 gave the best transformation in the presence of blunt - end ligation and also used for ligation mixture with competent cells (20%:100%). The recombinant PI3K C2 β C2 domain DNA sequence was achieved follows the path presented in Figure 10.

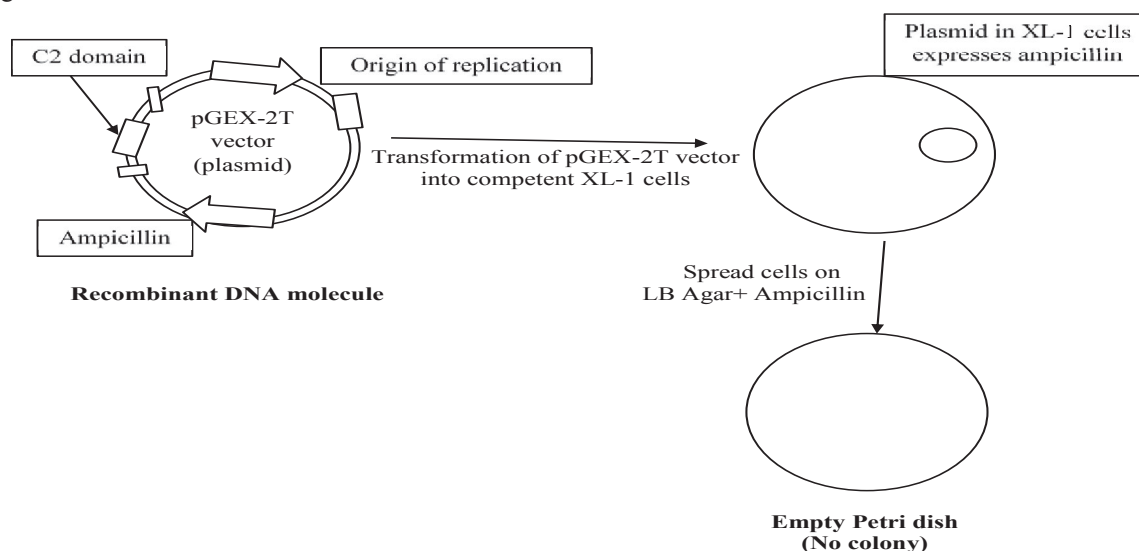

Figure 9: Schematic representation of the products obtained from ligation of the pGEX-2T vector + insert and transformation of XL-1 cells with the recombinant DNA molecule.

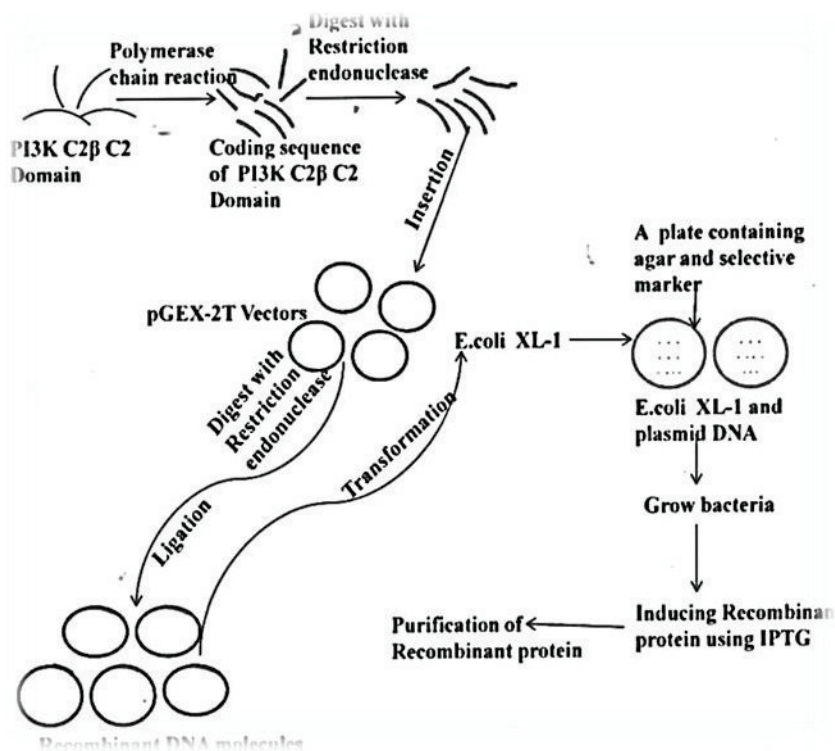

Figure 10: A schematic representation of the cloning of PI3K C2β C2 domain DNA sequence, expected expression and purification of recombinant C2 domain protein (GST+PI3K C2β C2 domain).

4. Conclusion

Ligated product was obtained from successful double digested products. Moreover, doubled of pGEX-2T vector using RE digestion proved to play a significant role in molecular cloning as a crucial area of biotechnology. It is uncertain if ligation worked as expected due to the absence of no colonies formed in the agar plates during transformation using molar ratio of 3:1. The produced recombinant DNA molecule was achieved at molar ratio of 5:1 and it can be employed for the production of recombinant proteins which will apparently be used in biomedical science, biotechnology, drug development and life science research for treatment of non - communicable diseases.

Acknowledgement

The authors thank Prof. Jan Domin and the laboratory scientists for their warm support.

References

- [1] M Kuure-Kinsey; B McCooley. The Basics of Recombinant DNA. Biochemical Engineering. (2000). <https://www.rpi.edu/dept/chem-eng/Biotech-Environ/Projects00/rdna/rdna.html>. Retrieved on 16 December 2016.
- [2] N. A. Campbell; J. B. Reece. Biology, 6th edition, San Francisco, Addison Wesley. 2002; 375-401. ISBN 0-201-75054-6.
- [3] P Walter; A Bruce; AS Johnson; J Lewis; MC Raff; K Roberts. Molecular Biology of the Cell, 5th Edition Extended version, New York: Garland Science. ISBN 0-8153-4111-3.
- [4] JM Berg; JL Tymoczko; L Stryer. Biochemistry, 7th edition, W.H. Freeman & Company. New York, 2010, 1 - 1026. ISBN 1-4292-2936-5.
- [5] JD Watson. Recombinant DNA: Genes and Genomes: A Short Course, San Francisco: W.H. Freeman and Company, New York, 2007, 1 - 474. ISBN 0-7167-2866-4.
- [6] Recombinant DNA technology. Genetics. Encyclopaedia Britannica. <https://www.britannica.com/science/recombinant-DNA-technology>. Retrieved on 16 December 2016.
- [7] SD Cederbaum; GC Fareed; MA Lovett; LJ Shapiro. Recombinant DNA in medicine. West J Med., 1984, 141(2), 210–222.
- [8] J Sambrook; EF Fritsch; T Maniatis. Molecular cloning: A laboratory manual, 2nd Edition, Cold Spring Harbor Laboratory Press, New York, 1989, 1 - 1626.
- [9] V Gupta; J Singh; R Bala; R Magazine. Recombinant DNA Therapy in Medicine. JK-Practitioner, 2003,

- 10(4), 315-318.
- [10] P Kumar. Top 5 Applications of Recombinant DNA Technology in Medicine. Biology Discussion, 2016.<http://www.biologydiscussion.com/dna/recombinant-dna-technology/top-5-applications-of-recombinant-dna-technology-in-medicine/11935> Retrieved on 16 December 2016.
- [11] AT Banigo; TO Azeez. Effect of Magnesium ions on Phosphoinositide-3-Kinase C2 β C2 Domain, *J Chem Pharm Res*, 2016, 8 (8), 1223 - 1228.
- [12] EA Nalefski; JJ Falke. The C2 domain calcium-binding motif: Structural and Functional diversity. *Protein Sci.*, 1996, 5 (12), 2375 - 2390.
- [13] A Arcaro; S Volinia; MJ Zvelebil; R Stein; SJ Watton; MJ Layton; I Gout; K Ahmadi; J Downward; MD Waterfield. Human phosphoinositide 3- kinase C2 beta, the role of calcium and the C2 domain in enzyme activity. *J. Biol. Chem.*, 1998, 273, 33082 - 33090.
- [14] J Domin; F Pages; S Volinia; SE Rittenhouse; MJ Zvelebil; RC Stein; MD Waterfield. Cloning of a human phosphoinositide 3-kinase with a C2 domain that displays reduced sensitivity to the inhibitor wortmannin. *Biochem J*. 1997, 326, 139 - 147.
- [15] J Malek; DH Haft. Conserved protein domains are maintained in an average ratio to proteome size. *Genome Biology*. 2001, 2, 80 - 90.
- [16] B Vanhaesebroeck; J Guillermet-Guibert; M Graupera; B Bilanges. The emerging mechanisms of isoform-specific PI3K signalling. *Nat. Rev. Mol. Cell. Biol.*, 2010, 11(5), 329 - 341.
- [17] pGEX-2T. Snap gene. [http://www.snapgene.com/resources/plasmid__files/pgex_vectors_\(ge_healthcare\)/pGEX-2T/](http://www.snapgene.com/resources/plasmid__files/pgex_vectors_(ge_healthcare)/pGEX-2T/) Retrieved on 15 December 2016.
- [18] DB Smith; KS Johnson. Single-step purification of polypeptides expressed in Escherichia coli as fusions with glutathione S-transferase. *Gene*, 1988, 67, 31 - 40.
- [19] WG Kaelin Jr; DC Pallas; JA DeCaprio; FJ Kaye; DM Livingston. Identification of cellular proteins that can interact specifically with the T/E1A-binding region of the retinoblastoma gene product. *Cell*, 1991, 64(3), 521-532.
- [20] T Chittenden; DM Livingston; WG Kaelin Jr. The T/E1A-binding domain of the retinoblastoma product can interact selectively with a sequence-specific DNA-binding protein. *Cell.*, 1991, 65(6), 1073 - 1082.
- [21] HG Vikis; KL Guan. Glutathione-S-transferase-fusion based assays for studying protein-protein interactions. *Methods Mol Biol.*, 2004, 261, 175-186.
- [22] CR Singh; K Asano. Localization and characterization of protein-protein interaction sites. *Methods Enzymol.*, 2007, 429, 139 - 161.
- [23] KS Johnson; GBL Harrison; MW Lightowers; KL O'hoy; WG Cogle; RP Dempster; SB Lawrence; JG Vinton; DD Heath; MD Rickard. Vaccination against ovine cysticercosis using a defined recombinant antigen. *Nature*, 1989, 338, 585 - 587.
- [24] E Fikrig; SW Barthold; FS Kantor; RA Flavell. Protection of mice against the Lyme disease agent by immunizing with recombinant OspA. *Science*, 1990, 250, 553 - 556.
- [25] SA Williams; BE Slatko; JR McCarrey. Laboratory Investigations in Molecular Biology, Jones and Barlett Publishers, Inc., USA, 2006, 1 - 235.

ALMA TAMUNONENGI OFORI BANIGO (AM'16-M'16) is a member of National Association of Biomedical Engineers and Technologists (formerly known as Nigerian Institute for Biomedical Engineering), Tissue Engineering Society and Organization for Women in Science for the Developing World in 2016. She also became a member of AuthorAID global network and Pregnurture (Non-profit Organization) in 2017. She hails from Rivers State, Nigeria. She obtained a Bachelor's degree in Plant Science and Biotechnology from University of Port Harcourt, Port Harcourt, Rivers State, Nigeria in 2010 and a Master of Science degree in Biomedical Engineering from University of Bedfordshire, Luton, England, United Kingdom in 2013. Her areas of specialization include biotechnology, biomaterials, cell/molecular/tissue engineering, mentoring relationships and gender equality, education as well as sustainable development.

TAOFIK OLADIMEJI AZEEZ (CM'10-CM'11) is a native of Ogbomoso in Oyo State, Nigeria. He earned a B.Tech degree from Ladoke Akintola University of Technology, Ogbomoso, Oyo State, Nigeria in 2001, M. Eng in 2009 and Ph.D from Nnamdi Azikiwe University, Awka, Nigeria. All in Chemical Engineering. A corporate member of Nigerian Society of Engineers in 2010, Nigerian Society of Chemical Engineers in 2011, Council of Regulation of Engineering in Nigeria (COREN) in 2010.